



MANUEL D'INSTRUCTIONS INSTRUCTION MANUAL

Pergola Viken 10 PI. X 13 PI.
Pergola Viken 10 FT. X 13 FT.

sku: PA1013-6211		
------------------	--	--

Sur réception de votre abri, nous vous conseillons de prendre en photo chaque côté de chacune des boîtes. Veuillez vérifier le contenu de chaque boîte à l'aide de la liste des pièces avant d'entamer l'assemblage de votre abri. Ne détruisez pas les boîtes avant que votre abri soit entièrement assemblé.

**10pi x 13pi / 3m x 4m Pergola
LES INSTRUCTIONS D'INSTALLATION**

IMPORTANT: RETENIR POUR LA FUTURE RÉFÉRENCE, LIRE ATTENTIVEMENT

Consultez vos autorités locales pour en savoir plus sur les lois municipales concernant l'installation des structures temporaires avant l'achat de votre abri. Certaines juridictions peuvent exiger des permis pour l'installation et l'utilisation.

Pour obtenir de l'assistance concernant certaines pièces, l'installation ou l'assemblage veuillez contacter notre équipe du service à la clientèle de Gazebo Penguin au numéro de téléphone mentionné ci-dessous. (Français, Anglais du Lundi au Vendredi de 8 00 à 16 :00 heure de l'Est)

Montréal: (514) 276-3485

Canada et États-Unis: 1-800-737-7174

******ATTENTION******

- Pour utilisation extérieure seulement.
- La neige doit être nettoyée en tout temps, ne jamais laisser s'accumuler.
- Conservez votre preuve d'achat dans un endroit sûr.
- L'assemblage peut durer plus de quatre (4) heures et exiger un minimum de trois (3) personnes.

Avant l'assemblage :

- Veuillez conserver toutes les boîtes pendant l'assemblage du gazebo.
- La structure doit être ancrée sur un sol plat et solide comme le béton ou de l'asphalte.
- Tenez-vous à l'écart des lignes électriques, des branches d'arbres et autres structures.
- Assurez-vous qu'il n'y ait pas de tuyaux ou fils souterrains avant de creuser.
- Assemblez la structure le plus près possible du point final d'utilisation.
- Nous vous recommandons fortement le port de gants, de lunettes de sécurité ainsi qu'un casque de protection lors de l'installation,
- Ne vous suspendez pas, ne grimpez pas et en aucun temps vous ne devez vous tenir ou prendre appui sur le toit.
- Avant l'assemblage, lisez bien les instructions et vérifiez que toutes les pièces soient présentes dans les boîtes. S'il y a un problème, contactez notre département de service garantie.

Vous aurez besoin : (Non-inclus)

- Un escabeau de 6 pieds (1.8m), un tournevis Phillips, un ruban à mesurer, un niveau, un maillet et une bâche sur laquelle vous placerez les pièces nécessaires à l'assemblage.

Instruction d'ancrage :

- Un ancrage adéquat du cadre à la base et au mur est nécessaire pour la sécurité.
- Une structure qui n'est pas solidement ancrée risque de s'envoler ou se déplacer lors de vents violents causant des dommages et de hauts risques de blessures.
- Le matériel et les outils requis pour l'ancrage varient en fonction de l'emplacement d'installation **et ne sont pas fournis.**
- Veuillez vérifier auprès de votre quincaillerie locale pour plus d'informations au sujet des ancrages les plus appropriés pour votre surface.
- N'utilisez pas de dalles de chaussée ou de pavés uni pour vos ancrages car cela ne constitue pas une fondation stable et solide.











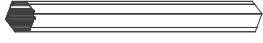
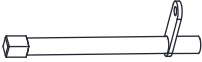
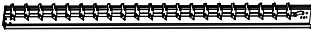

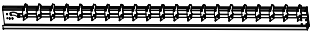

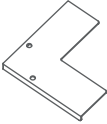

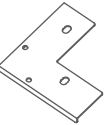
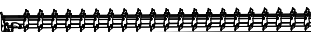
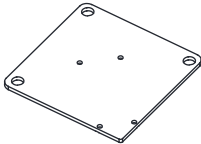

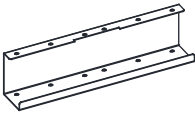

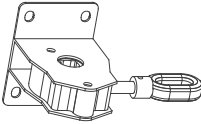

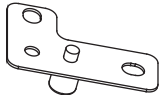

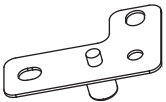

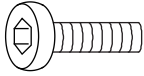

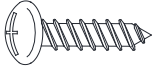

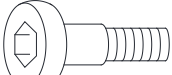

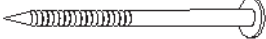
Soin et Maintenance :

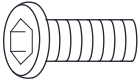

- En cas de pièces défectueuses, manquantes, endommagées ou pour toute autre question concernant ce produit, n'hésitez pas à nous contacter au : (514) 276-3485 ou 1-800-737-7174
- Veuillez avoir la liste des pièces ainsi que leurs numéros à portée de main lors de votre appel avec notre équipe du service à la clientèle.

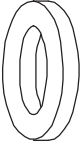
Structure et Panneaux de toit :

- Nettoyez doucement avec une solution savonneuse écologique, de l'eau claire à l'aide d'une éponge et ensuite, laissez sécher à l'air libre.
- N'utilisez jamais de matériaux abrasifs, de brosses métalliques, de produits chimiques, de nettoyeurs puissants ou de l'eau de javel.
- Si vous retirez les panneaux de toit pour les nettoyer, assurez-vous que les panneaux soient complètement secs avant de les réinstaller.
- N'utilisez jamais de nettoyeur haute pression.

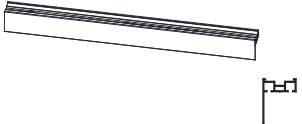
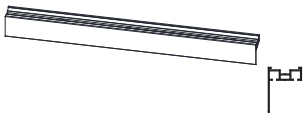
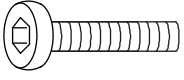
PART	PACKED IN BOX	QTY	DIAGRAM	PART	PACKED IN BOX	QTY	DIAGRAM
23-227 Poutre En Coin A	1	4		23-197 Bielle H1	2	2	
23-228 Traverse Gauche B	2	1		23-198 Bielle H2	2	2	
23-229 Traverse Droite C	2	1		23-199 Manivelle Du Treuil H3	2	1	
23-189 Traverse Avant D1	2	1		23-200 Capuchon De Poutre I	2	2	
23-190 Traverse Avant D2	2	1		23-234 Capuchon De Poutre I1	2	2	
23-230 Traverse Centrale E	2	1		23-201 Plaque D'Ancrage J	2	4	
23-232 Traverse Arrière F1	2	1		23-235 Connecteur L	2	2	
23-233 Traverse Arrière F2	2	1		23-204 Treuil M	2	2	
23-195 Volet G	3	20		23-236 Connecteur À bascule N1	2	2	
	4	22					
23-196 Plaque De Recouvrement G1	4	2		23-237 Connecteur À bascule N2	2	2	

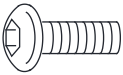
PART	PACKED IN BOX	QTY	DIAGRAM	PART	PACKED IN BOX	QTY	DIAGRAM
23-205 Boulon AA	2	40	 M6*15MM	23-212 M6 Rondelle HH	2	76	
23-206 Boulon BB	2	8	 M5*15MM	23-213 Capuchon En Plastique II	2	12	
23-207 Boulon CC	2	4	 M6*10MM	23-214 Clé JJ	2	1	
23-208 Vis DD	2	12	 M6*65MM	23-215 Clé Hexagonale KK	2	1	
23-209 Boulon EE	2	168	 M5*8MM	23-216 Clé Hexagonale LL	2	1	 4#
23-210 Écrous FF	2	4	 M6	23-217 Clé Hexagonale MM	2	1	 6#
23-211 M8 Rondelle GG	2	4		23-219 Boulon OO	2	16	 M5*25MM
23-223 Clé Hexagonale RR	2	1	 3#	24-120 Tubes De Rail P1	1	2	
24-121 Tubes De Rail O1	1	2		24-122 Tubes De Rail P2	1	2	
24-127 Tubes De Rail O2	1	2		24-123 Boulon VV	2	8	 M6*25MM

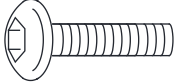
PART	PACKED IN BOX	QTY	DIAGRAM	PART	PACKED IN BOX	QTY	DIAGRAM
24-124 Boulon WW	2	12	 <p>M6*15MM</p>	24-126 M6 Rondelle UU	2	8	
24-125 Boulon XX	2	24	 <p>M6*25MM</p>				

Étape 1

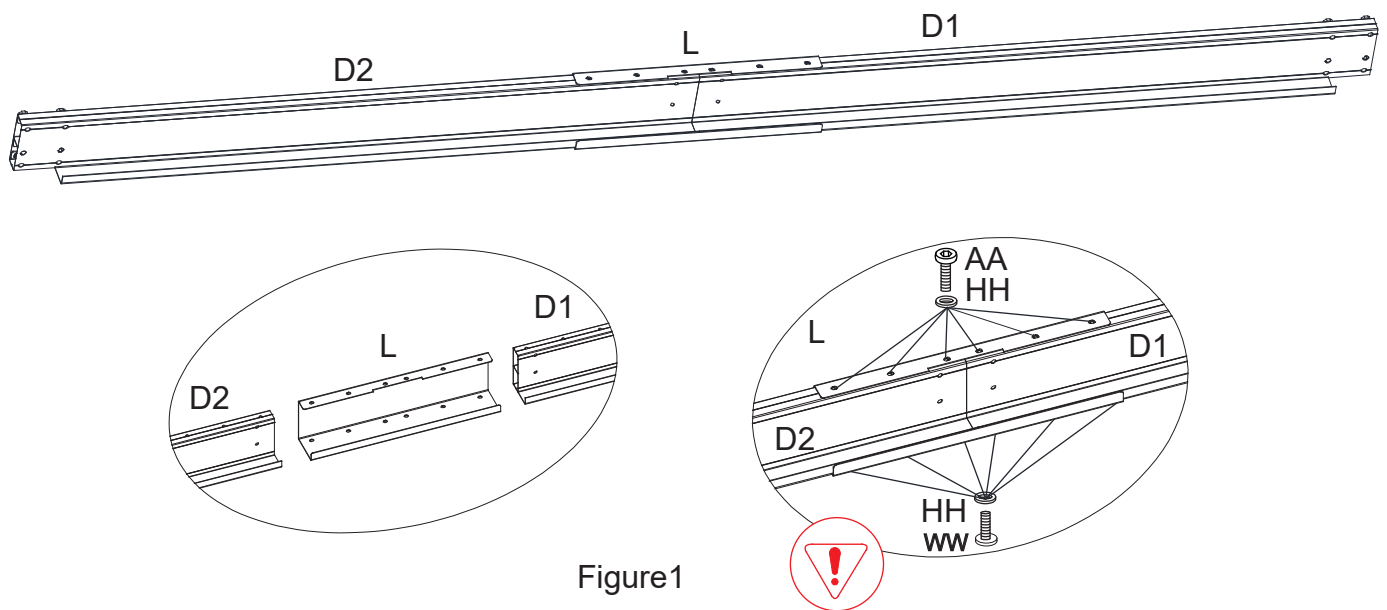

Figure1

Figure 1. Faites glisser la traverse (D1) et la traverse (D2) dans le connecteur (L) à l' aide des boulons (AA/WW) et des rondelles (HH).

Étape 2

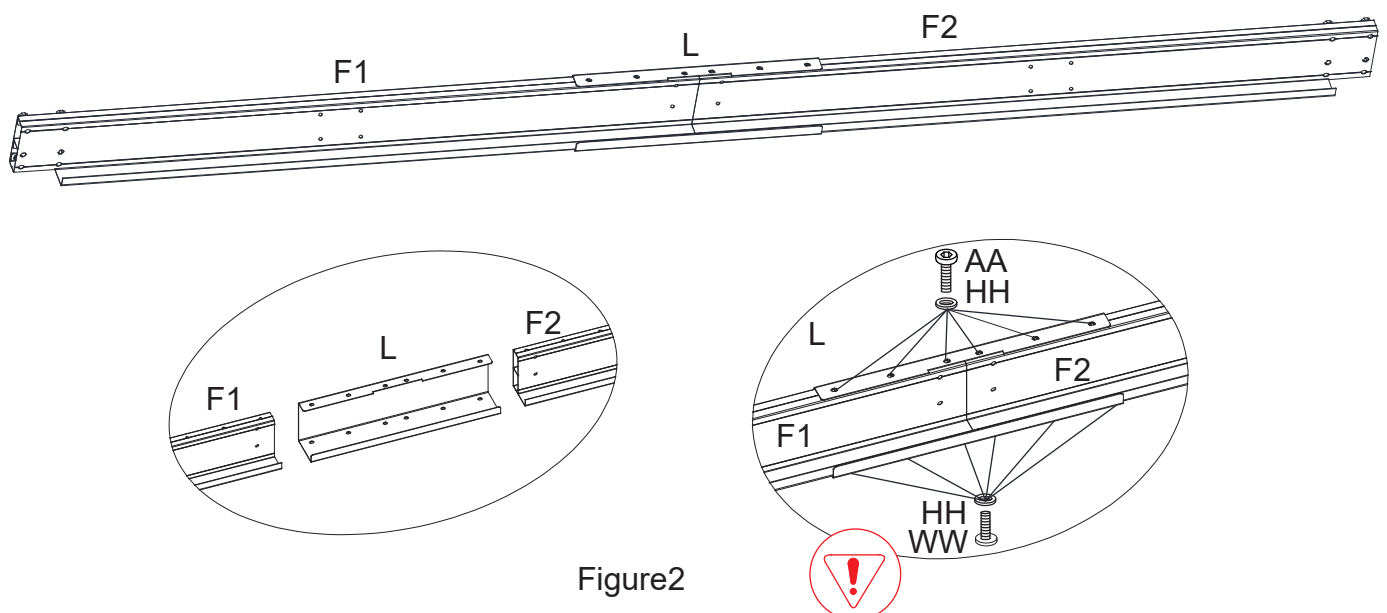

Figure2

Figure 2. Faites glisser le connecteur (L) dans les traverses arrière (F1/F2) à l' aides des boulons (AA/WW) et des rondelles (HH).

Remarque : Faites attention au sens de montage du connecteur (L).

Étape 3

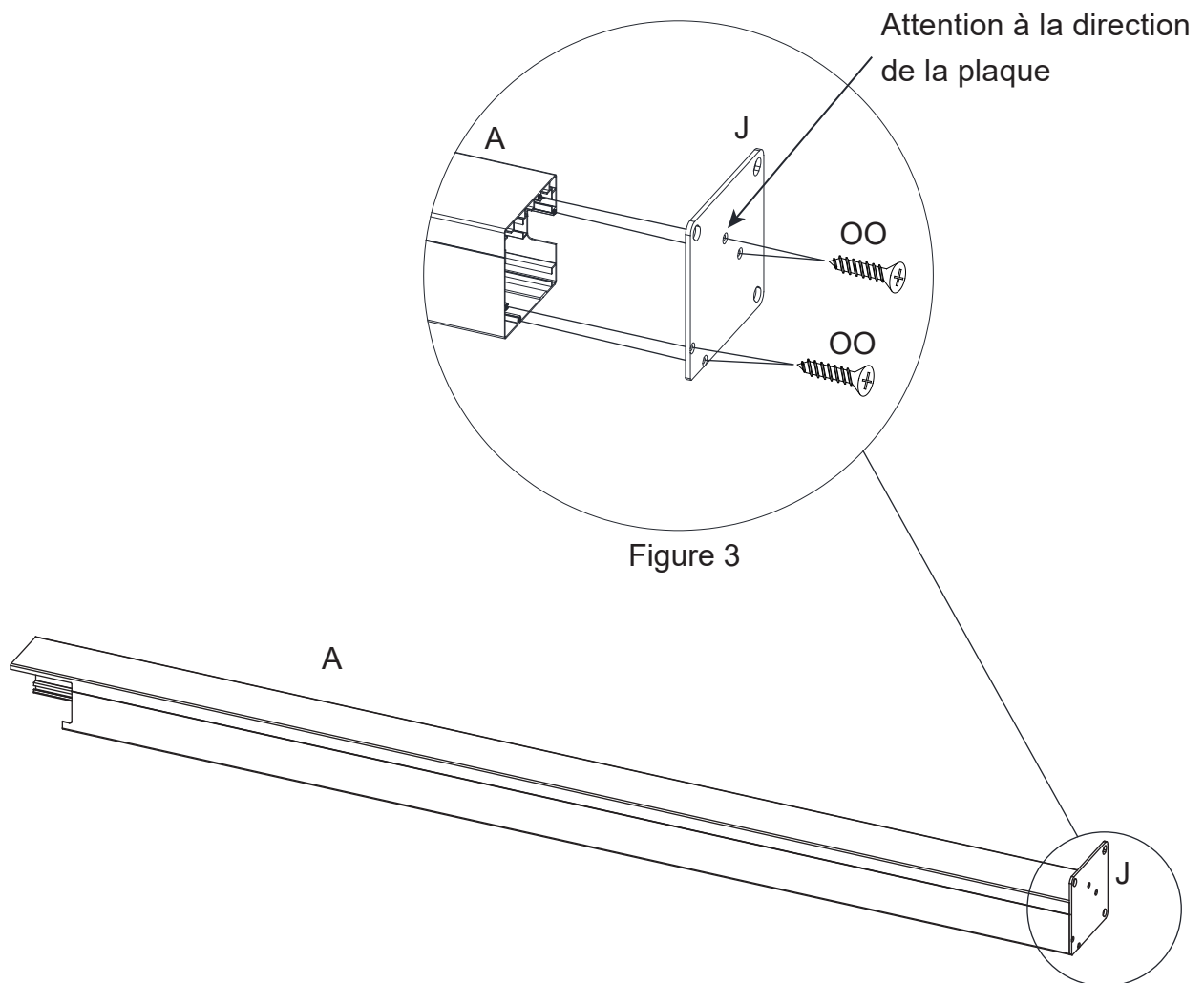

Figure 3. Reliez la plaque d' ancrage (J) à la poutre en coin (A) à l' aide des boulons (OO).

Étape 4

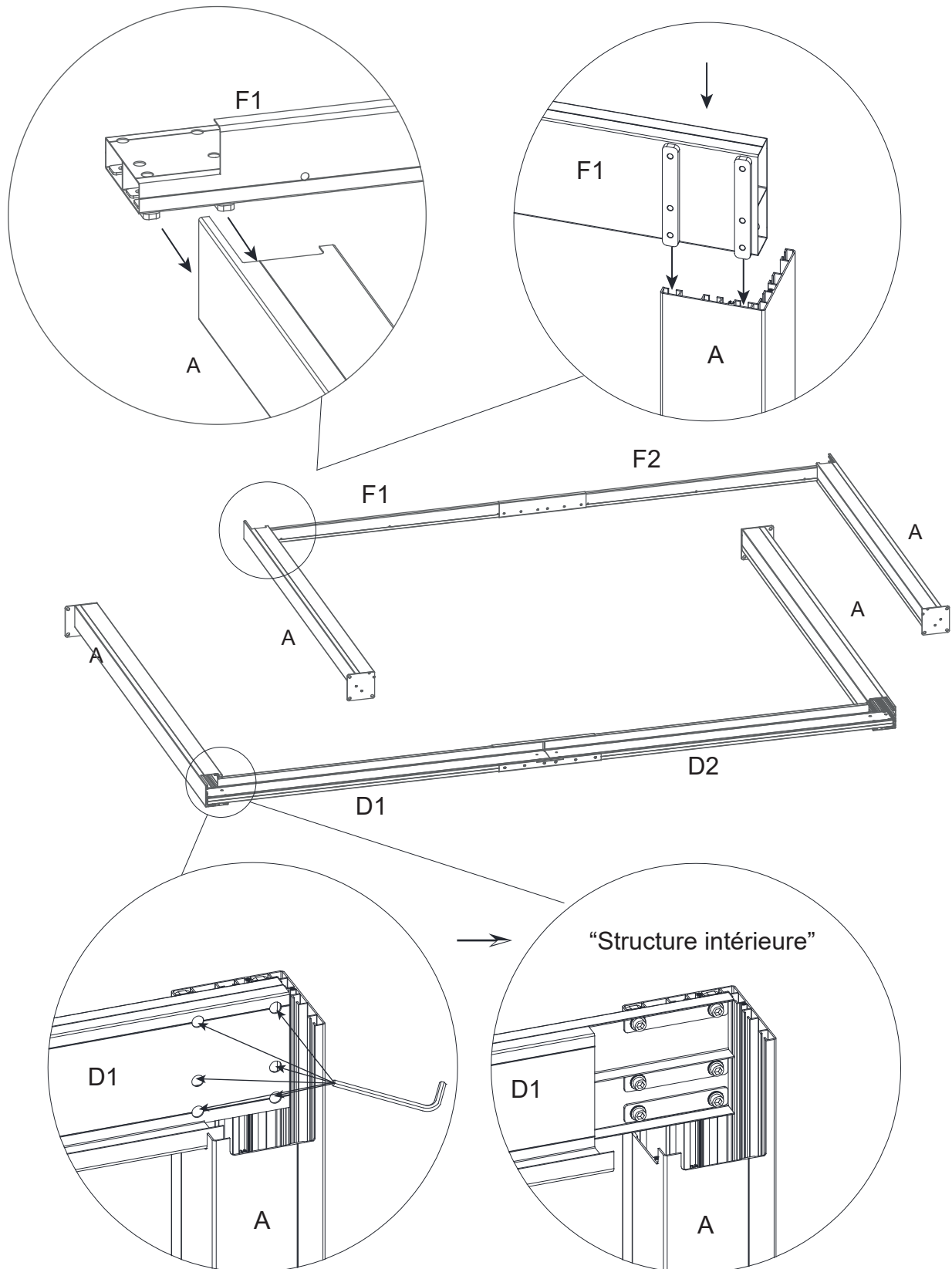

Figure 4

Figure 4. Glissez les deux extrémités des traverses avant (D1/D2) ainsi que les traverses arrière (F1/F2) dans le guide intégré de la poutre en coin (A) et serrez les boulons à l'aide de la clé hexagonale. Référez-vous au schéma de la structure interne.

Étape 5

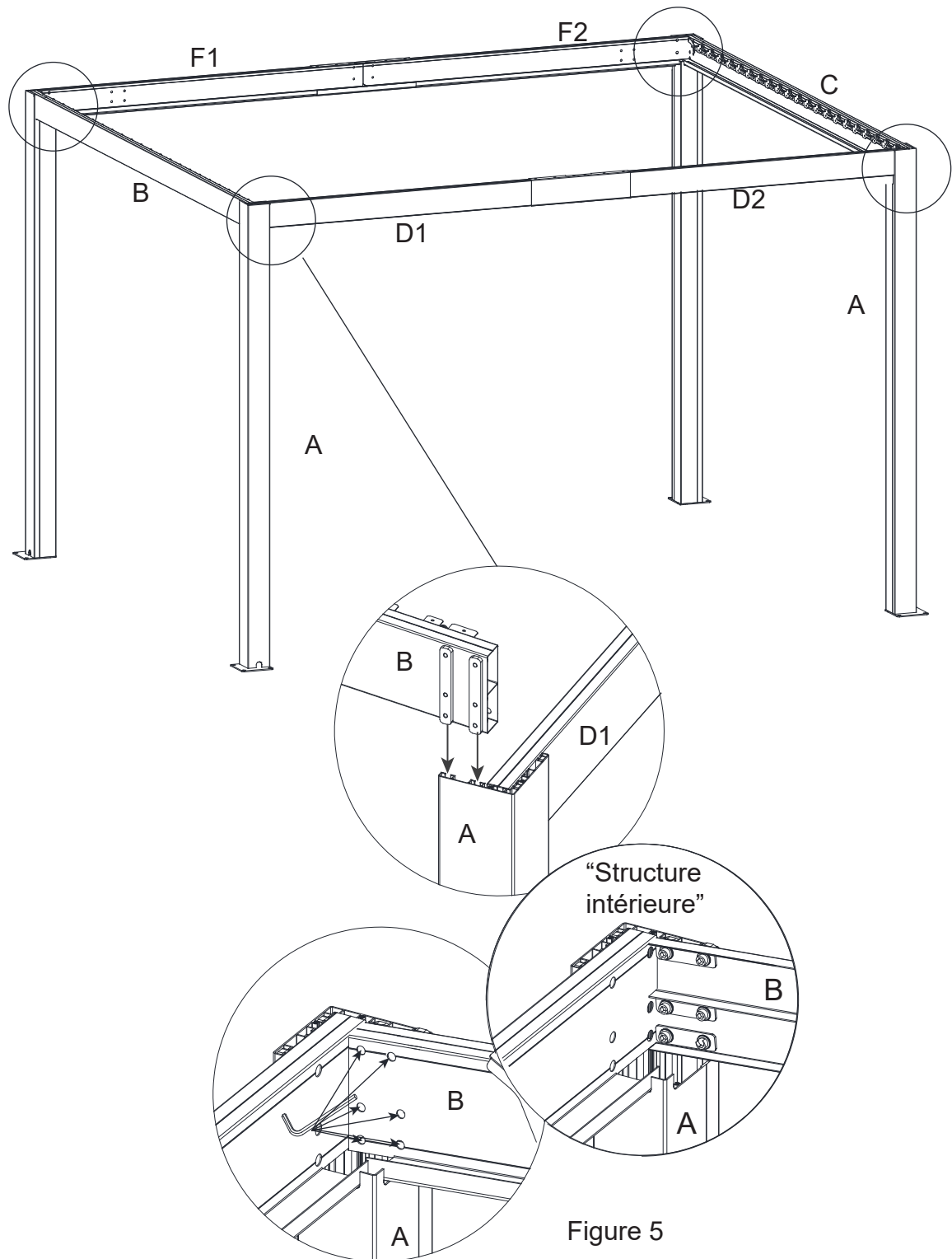

Figure 5. Faites glisser une extrémité des traverses (B/C) dans le guide intégré de la poutre en coin (A) et serrez les boulons à l' aide de la clé hexagonale.

Étape 6

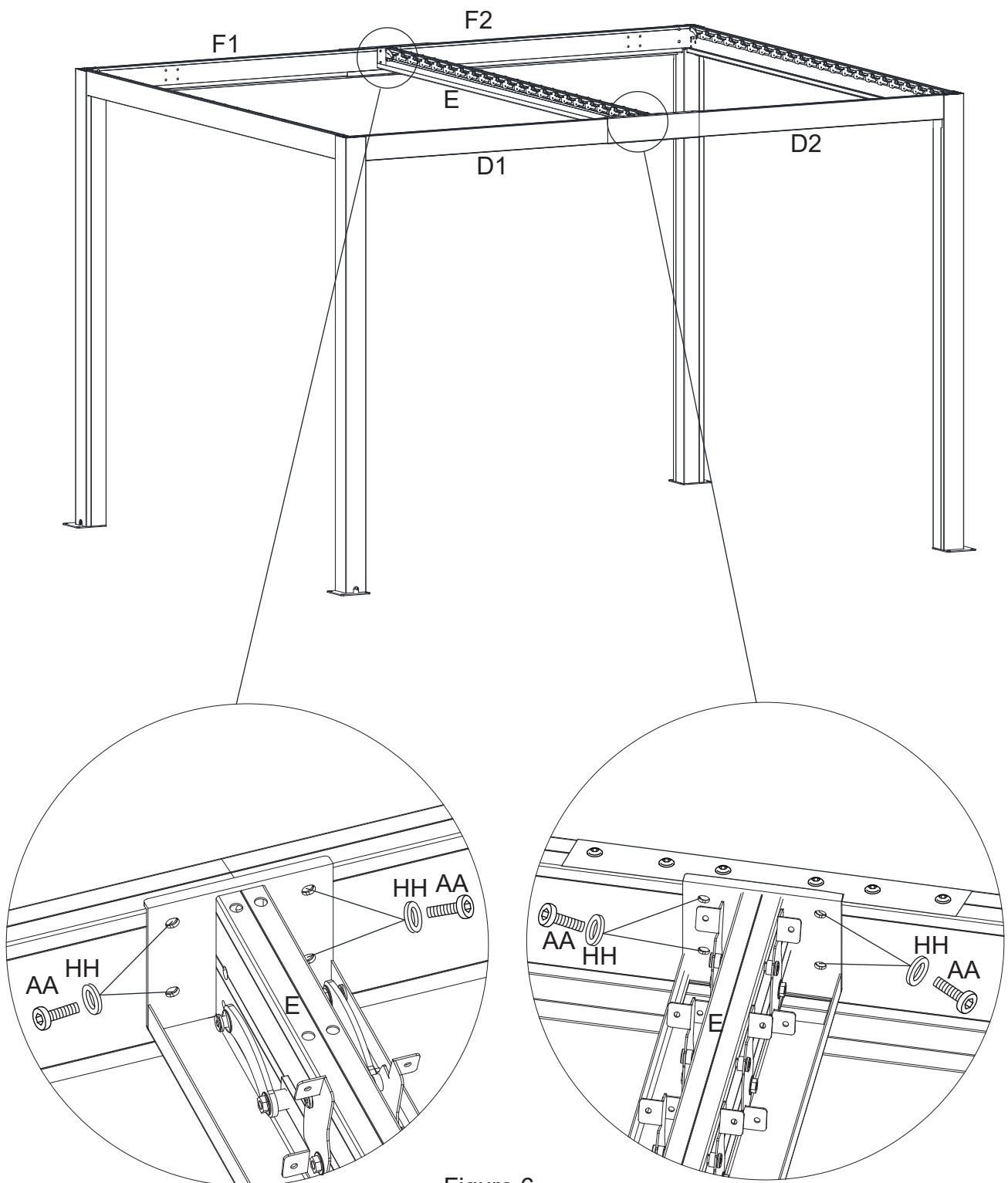

Figure 6

Figure 6. Reliez une extrémité de la traverse centrale (E) aux traverses avant (D1/D2) et l'autre extrémité de la traverse centrale (E) aux traverses arrière (F1/F2), 0α l' aide des boulons (AA) et des rondelles (HH).

Étape 7

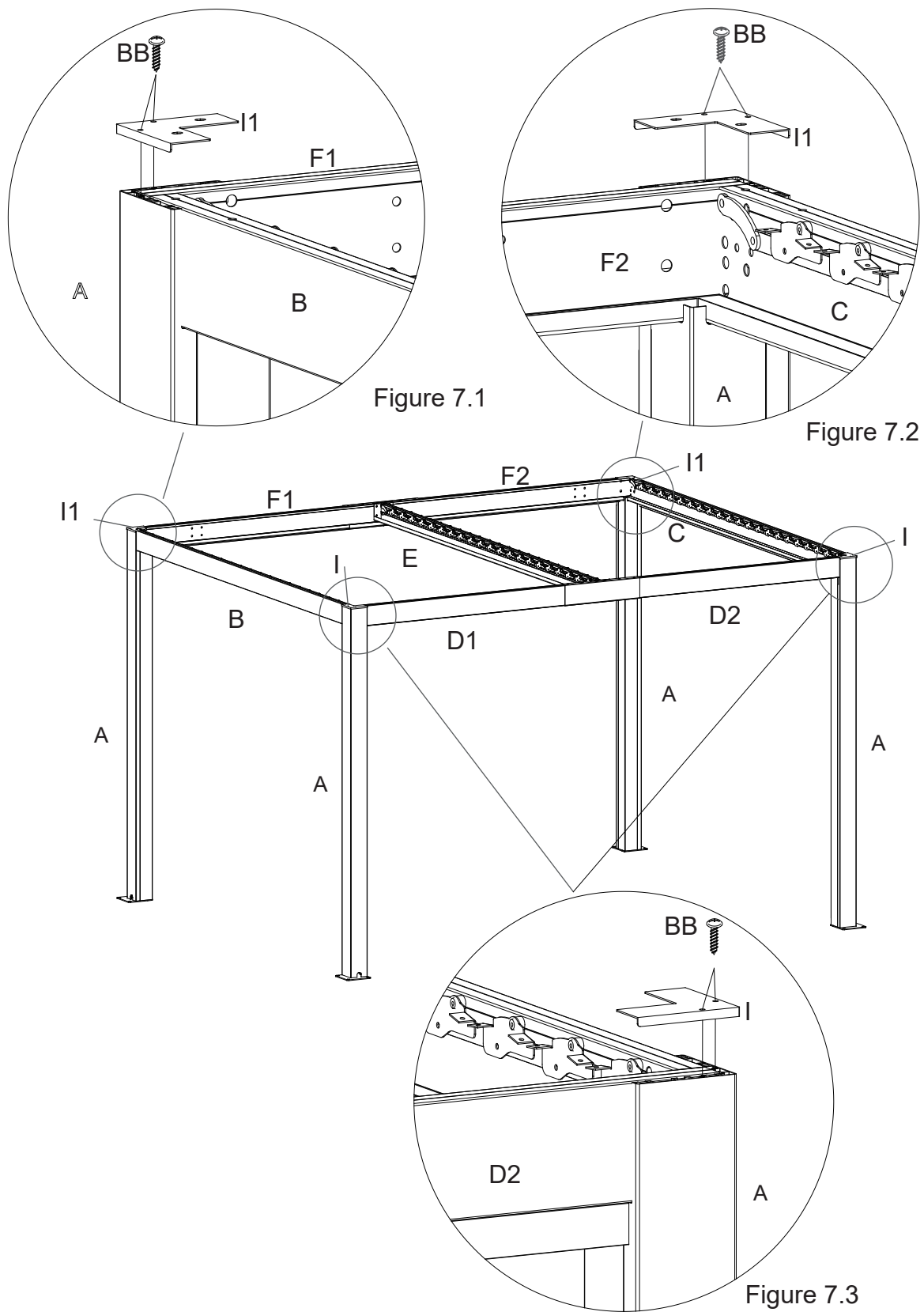

Figure 7.1-7.3. Connectez les doublures de capuchon (I/I1) à la poutre en coin (A) et fixez à l'aide des boulons (BB).

Étape 8

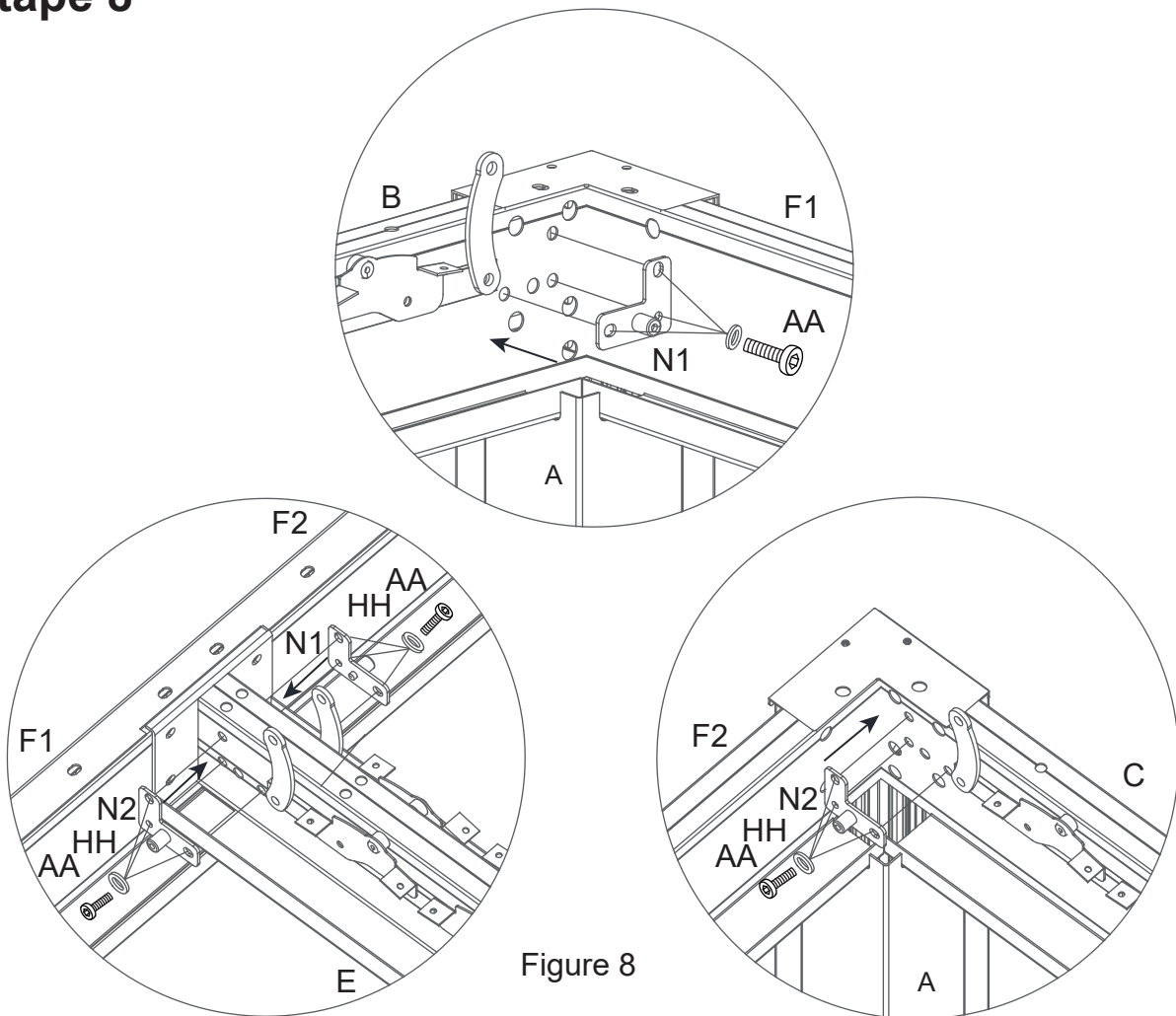

Figure 8. Fixez le connecteur à bascule (N1/N2) aux traverses (B/C/E) à l' aide des boulons (AA) et des rondelles (HH).

Étape 9

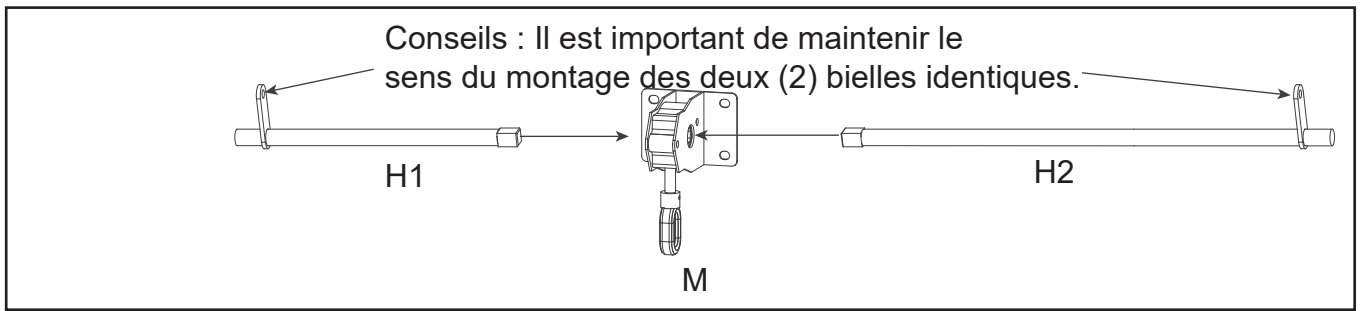

Figure 9.1

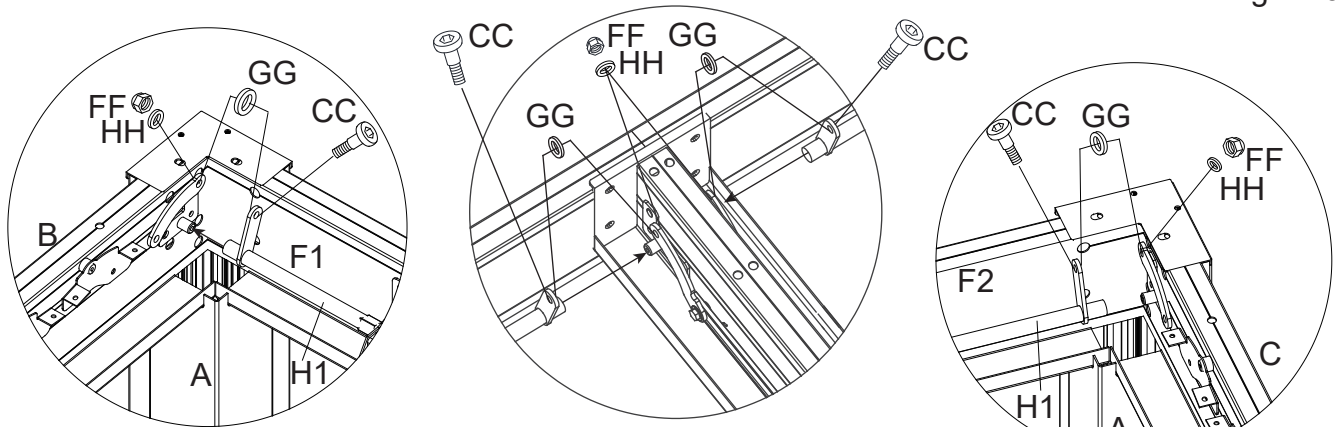

Figure 9.3

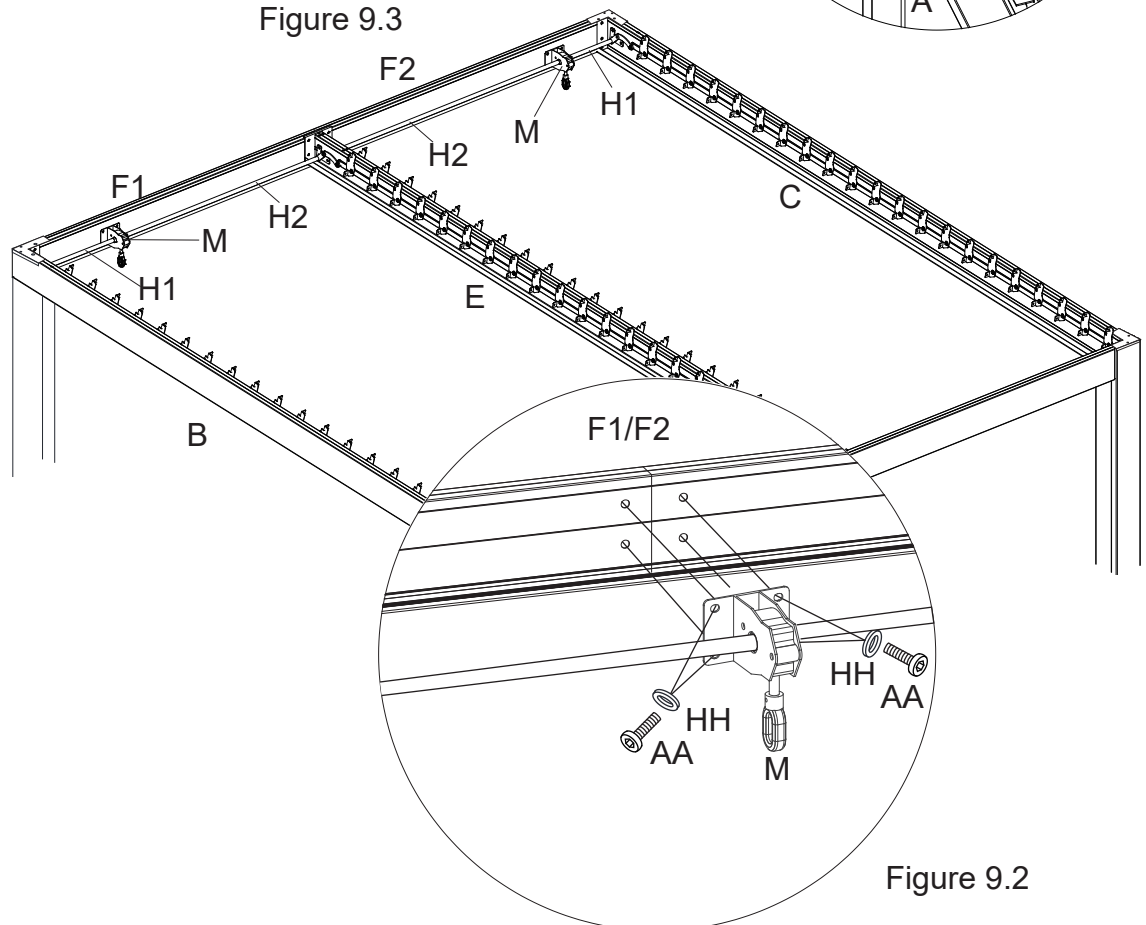

Figure 9.2

Figure 9.1-9.3. Insérez une extrémité des tiges de connexion (H1/H2) dans le treuil (M), puis fixez le treuil (M) aux traverses arrière (F1/F2) à l' aide des boulons (AA) et des rondelles (HH). Fixez ensuite l' autre extrémité des bielles (H1/H2) aux traverses (B/C/E) à l' aide des boulons (CC), des rondelles (GG/HH) et des écrous (FF).

Étape 10

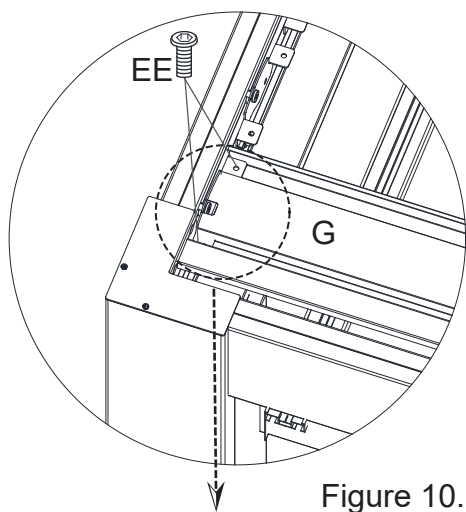

Figure 10.1

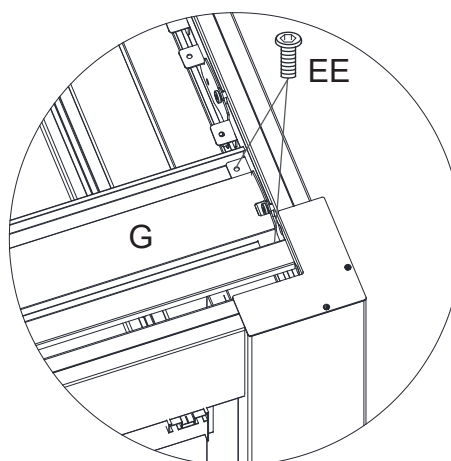

Figure 10.2

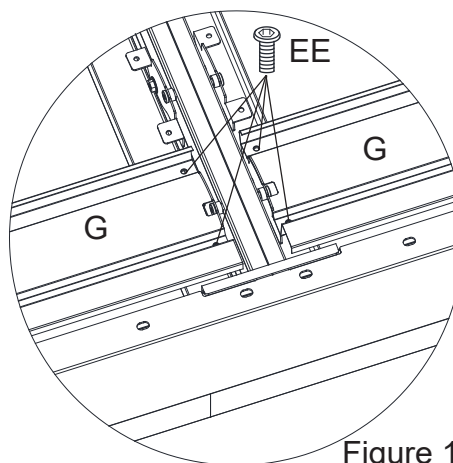
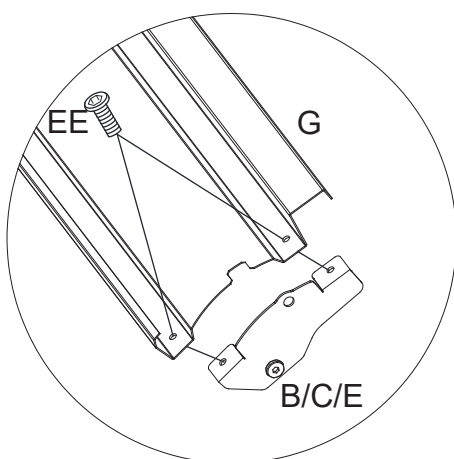

Figure 10.3

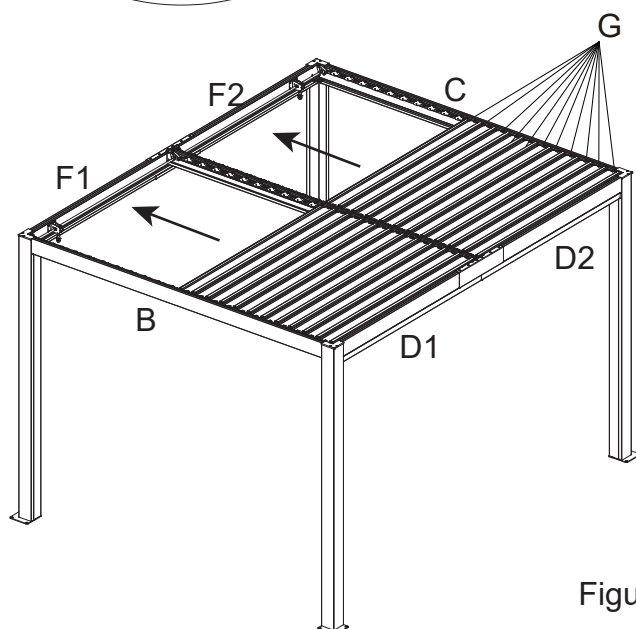

Figure 10.4

Figure 10.1. Connectez les volets (G) aux traverses (B/C/E) à l' aide des boulons (EE).

Figure 10.2. Assemblez les autres volets (G) dans dans le sens des flèches et fixez avec les boulons (EE). Référez-vous à la Figure 10.4.

Étape 11

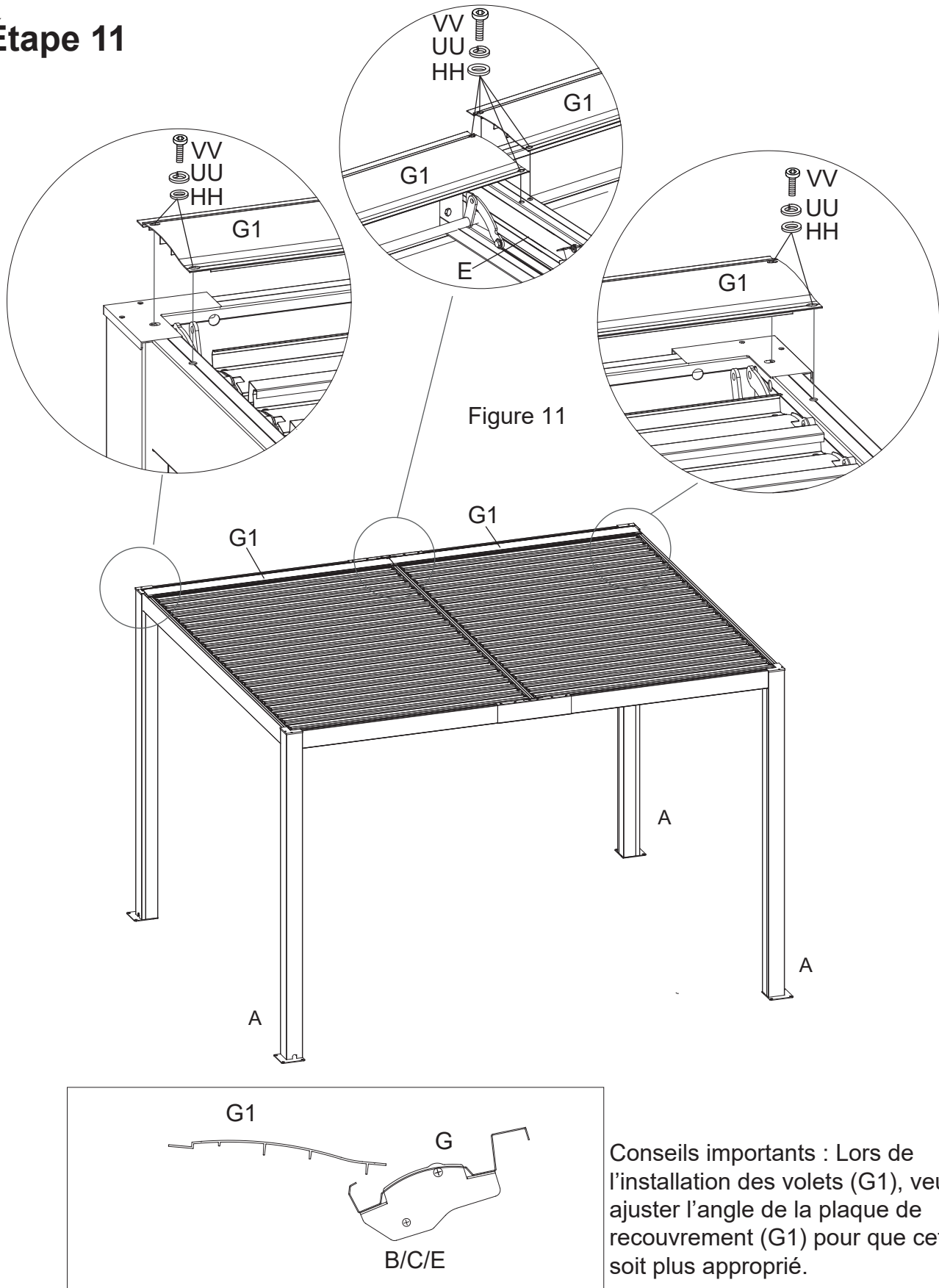

Figure 11. Connectez la plaque de recouvrement (G1) aux traverses (B/C/E), en les fixant avec les boulons (VV) et les rondelles (HH/UU).

Étape 12

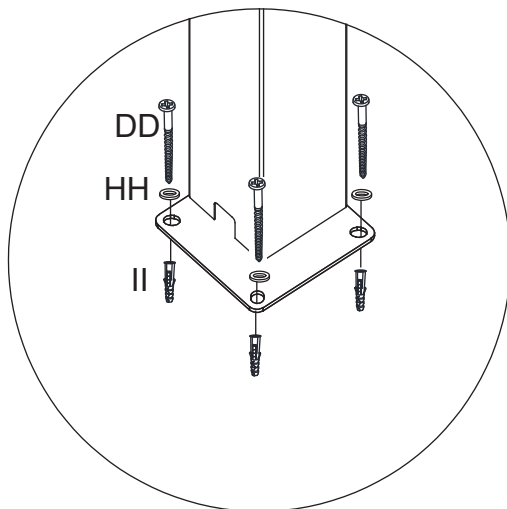
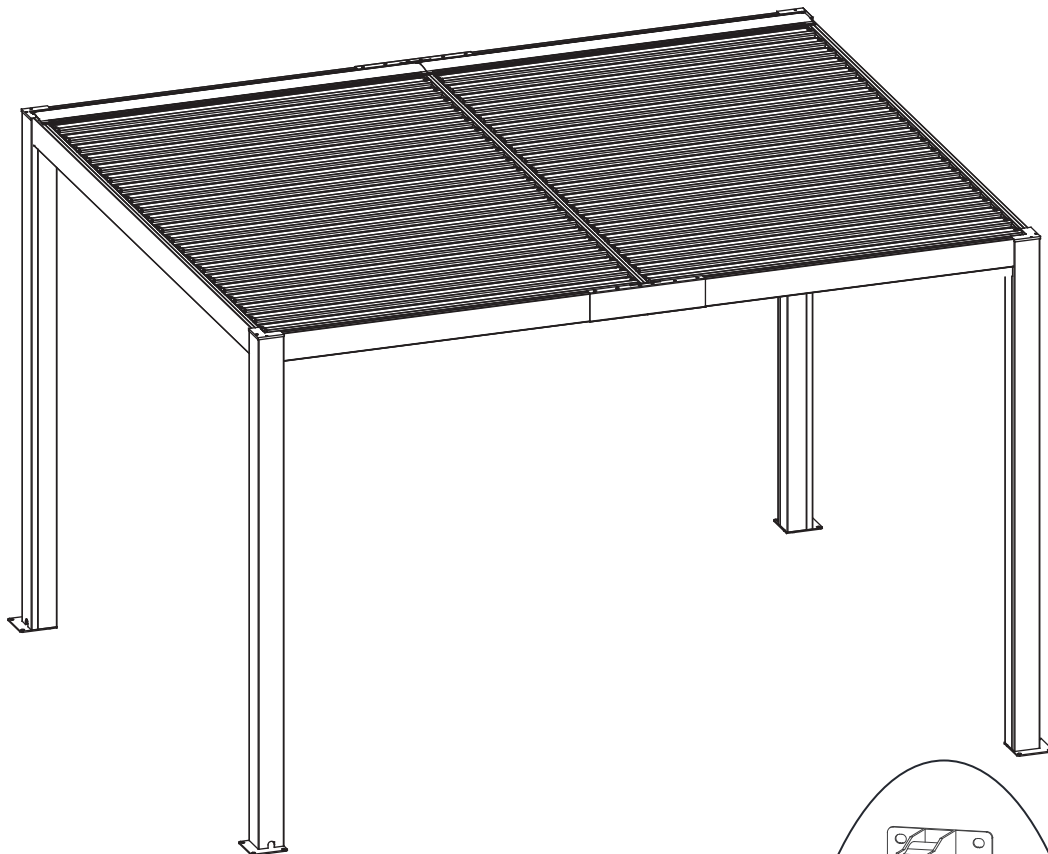

Figure 12.1

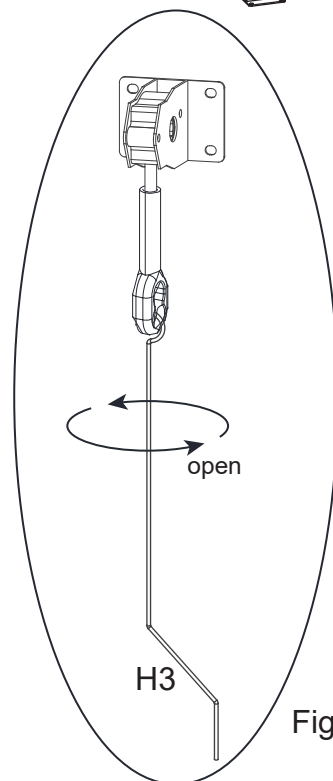

Figure 12.2

Figure 12.1. Fixez la pergola sur la terrasse à l' aide des vis (DD), des rondelles (HH) et des capuchons en plastique (II) pour s' assurer de la solidité de la structure.

Figure 12.2. Insérez la manivelle (H3) dans le treuil (M). Ceci vous permettra d' ouvrir et de fermer les volets (G).

Étape 13

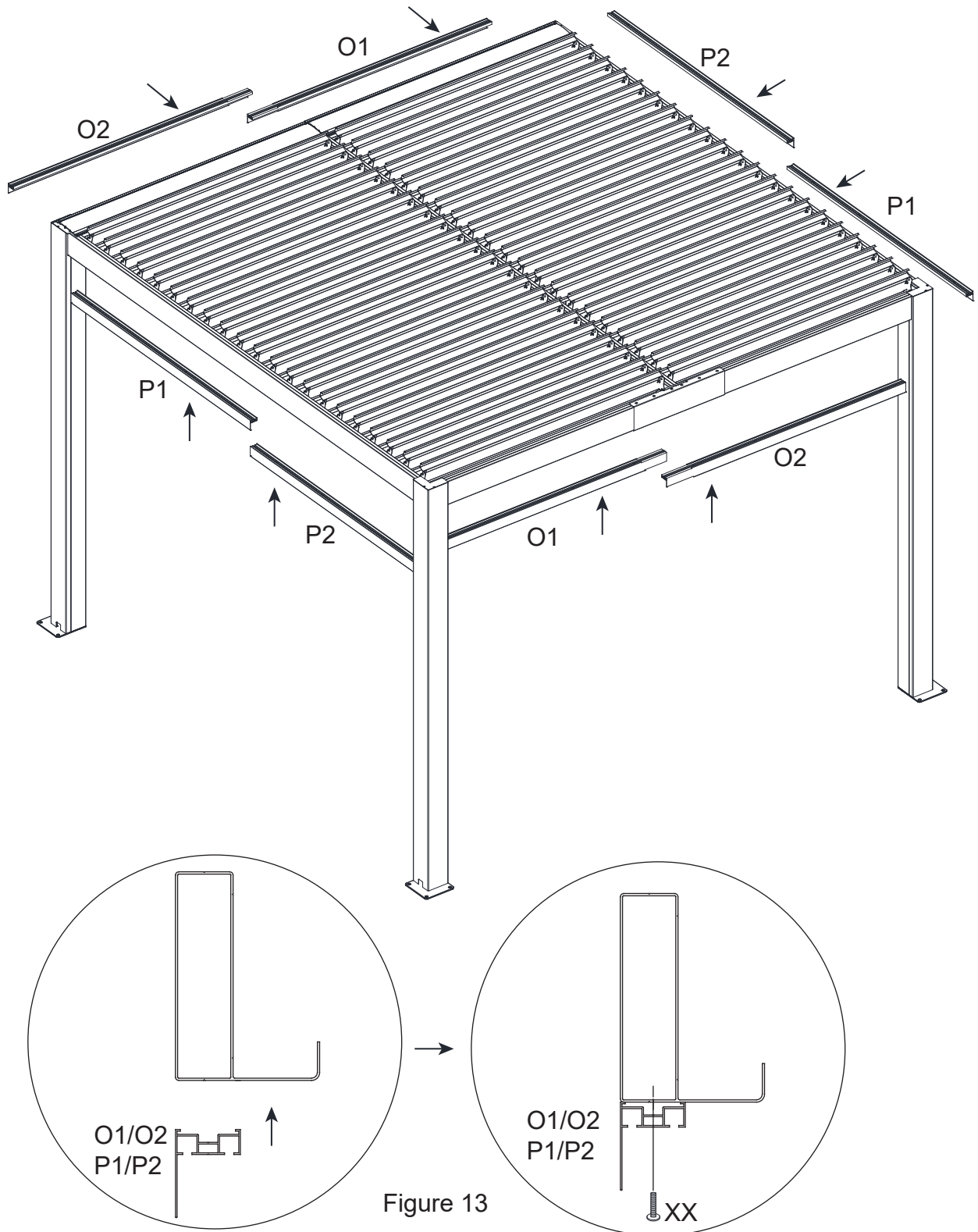
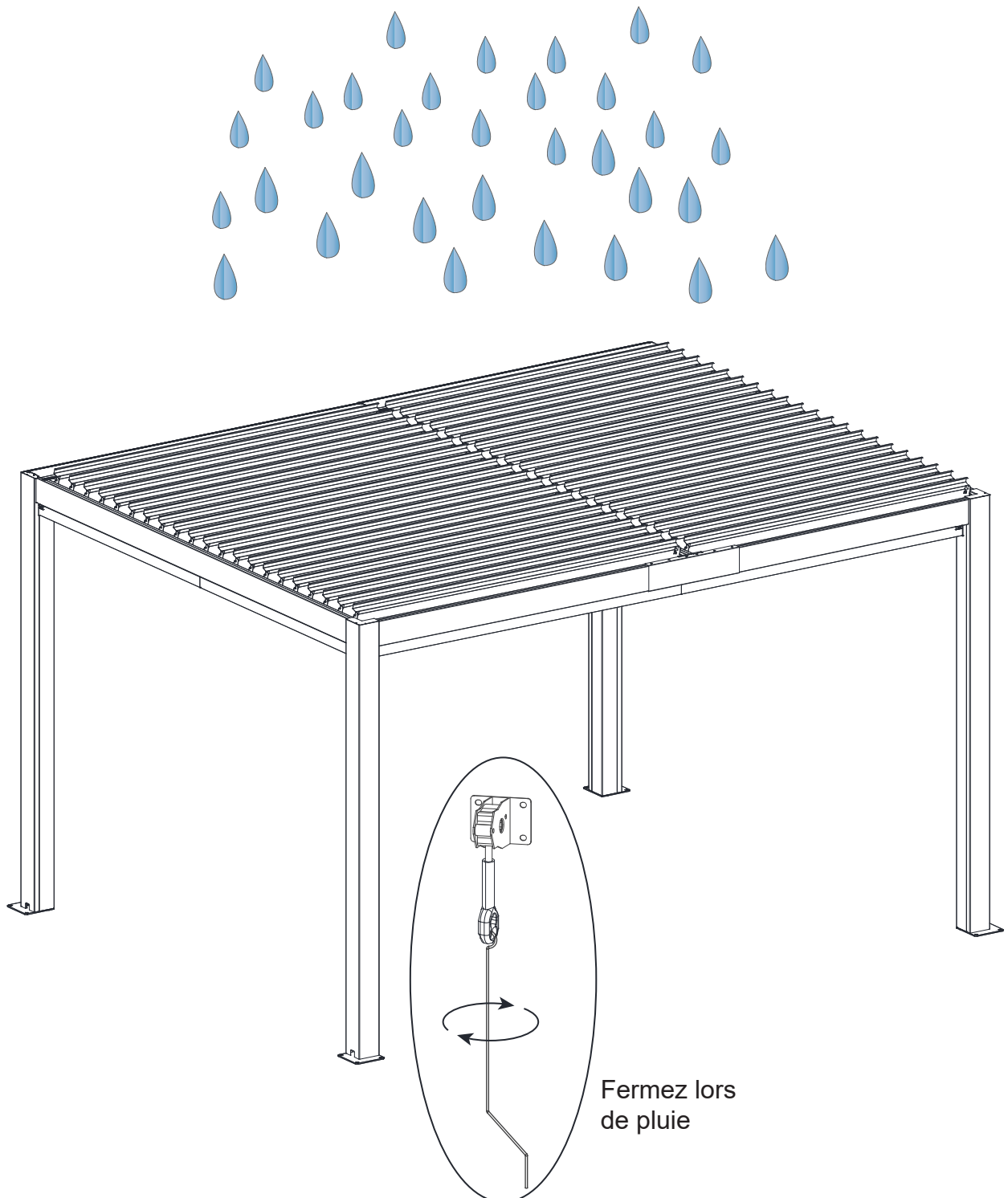

Figure 13. Connectez les tubes de rail (O1/O2/P1/P2) aux traverses en les fixant avec les boulons (XX).

Conseil Judicieux:

Après la pluie, veuillez ouvrir lentement les volets afin d'éviter que l'eau résiduelle n'éclabousse.



GARANTIE

Inspectez soigneusement le contenu de l'emballage afin de vérifier que toutes les pièces soient dans les boîtes et qu'elles soient intactes. S'il manque des pièces ou si celles-ci sont endommagées, **NE RETOURNEZ PAS le produit à l'endroit où vous l'avez acheté** ; contactez plutôt le Département d'Expérience Client de Gazebo Penguin.

Montréal : (514) 276-5643

Ailleurs au Canada et États-Unis : 1-800-737-7174

info@gazebopenguin.com

Ce produit a été conçu et fabriqué afin de répondre aux normes les plus exigeantes en matière de qualité et de durabilité. Sous réserve des sections « conditions d'application de la garantie » et des « limitations à la garantie » ci-dessous, il est garanti contre les défauts matériels ou de fabrication :

• 1 AN SUR LES DÉFAUTS MANUFACTURIERS

Advenant que le produit soit endommagé ou que la période de garantie soit expirée, veuillez contacter le département d'expérience client de Gazebo Penguin afin d'obtenir une liste complète des pièces de remplacement et des prix.

LIMITATIONS ET EXCLUSIONS À LA GARANTIE

1. Ce produit n'est pas garanti contre les dommages causés par le vent, la chute d'objets, le feu, les animaux, la végétation, le vandalisme et les conditions climatiques extrêmes
2. Les effondrements d'abris causés par une accumulation de neige, de glace et de vents
3. Le toit doit être maintenu libre en tout temps d'accumulation de neige et de glace.
4. Tous les dommages pouvant être causés par des accumulations de neige et de glace ne sont pas couverts par la garantie. La neige et la glace doivent être enlevées du toit, de la droite vers la gauche, par sections de cinq pieds (5) à la fois.
5. L'enlèvement de la neige et de la glace du produit fait par l'intérieur peut endommager ledit produit et de plus causer possiblement des blessures graves à la (aux) personne(s) impliquée(s) à l'enlèvement question.
6. Il est fortement recommandé que le produit ne soit pas placé de manière adjacente à un immeuble ou des arbres, car la neige ou la glace peut glisser sur le toit. Advenant que le produit soit placé de manière adjacente à un immeuble ou un arbre, des précautions supplémentaires doivent être prises afin de s'assurer qu'il n'y a aucune accumulation de neige ou de glace pouvant causer un poids excessif au produit.
7. Le produit ne sera garanti que s'il est installé conformément aux instructions écrites de Gazebo Penguin incluses avec le produit.
8. Des fuites dues à de fortes pluies peuvent survenir. Veuillez-vous référer au manuel d'instructions pour les positions des fenêtres et des informations sur la façon d'évacuer l'eau.
9. Le produit n'est pas garanti s'il a été ancré incorrectement.
10. Nous nous réservons le droit de remplacer ou réparer tout produit ou pièce défectueuse à notre seule discrétion.
11. Aucune modification ou ajout au produit n'est autorisée. Cela annulera votre garantie.



MANUEL D'INSTRUCTIONS INSTRUCTION MANUAL

Pergola Viken 10 PI. X 13 PI.
Pergola Viken 10 FT. X 13 FT.

sku: PA1013-6211		
------------------	--	--

**DO NOT DESTROY THE BOXES UNTIL COMPLETELY ASSEMBLED
FOR FUTURE REFERENCE,
TAKE PICTURES OF ALL SIX SIDES OF EACH OF THE BOXES UPON RECEIPT.
PLEASE VERIFY THE CONTENT OF EACH BOX AGAINST THE LIST OF PARTS**

10ft x 13ft / 3m x 4m Pergola

Instruction Manual

IMPORTANT: RETAIN FOR FUTURE REFERENCE, READ CAREFULLY

Consult with your local governing authority / local municipal codes regarding installation of temporary structures before purchase or assembly. Some jurisdictions may require permits for, or otherwise regulate, installation and use.

For assistance with assembly, installation, parts, or customer service, contact Gazebo Penguin Customer Service Department at the numbers listed below (English & French, Mon-Fri 8:00 AM to 4:00 PM EST):

Montreal: (514) 276-3485

Elsewhere in Canada and the US: 1-800-737-7174

WARNING:

- For outdoor use.
- Snow should be regularly cleared from the roof and not allowed to accumulate.
- Retain your **proof of purchase** for warranty purposes. Also keep the **original boxes** until the installation is complete and correct.
- The unit may take more than 4 hours and 3 people are required for this assembly.



PRIOR TO ASSEMBLY:

- Please don't destroy boxes until completely assembled.
- The foundation must be level, flat, and solid, such as concrete or asphalt.
- Keep away from overhead utility lines, tree branches, and other structures.
- Check for underground pipes or wires if digging or drilling is required.
- Do not install near roof lines or other structures that could shed snow, ice, or excessive rain run-off onto the roof top.
- Assemble the structure as close to its final location as possible.
- It is recommended to wear safety gloves, safety glasses, and hard hats for installation.
- Do not hang from, climb on, or stand on the structure or roof.
- Before assembly, read instructions and check that all parts are present in the boxes. If any parts are missing, refer to warranty information.
- A 6ft (1.8m) stepladder, Phillips screwdriver, tape measure, level, mallet, and a tarp to place parts on will be required for assembly (not included).
- Remove top protective film from roof panels prior to assembly; DO NOT remove bottom protective film until ready to insert roof panels, so as to identify which side is on top.

ANCHORING INSTRUCTIONS:

- Proper anchoring of the frame to the base and the wall is required for safety.
- Any structure not anchored securely has the potential to fly away during high wind causing damage and safety hazard.
- How the item is anchored, and the hardware and tools required, will vary based upon the set up location and are not provided.
- Please check with your local hardware store if for the appropriate anchors for your surface.
- Do not anchor to pavers / pavement slabs because they are not a solid foundation.
- Periodically check the anchors to ensure they remain secure

CARE AND MAINTENANCE:











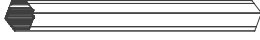

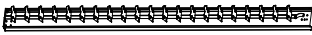

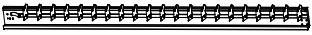

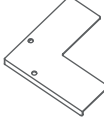
- In case of a defective or damaged part, or for any other questions concerning the product, please contact the manufacturer directly.
- Please have the parts list and part numbers on hand when ordering or requesting replacement parts.

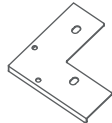
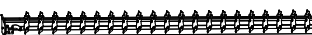
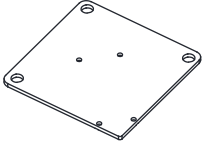

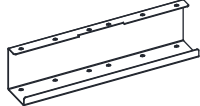

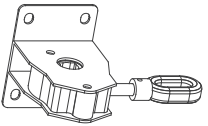

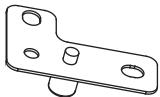

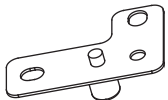

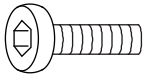

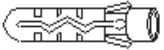
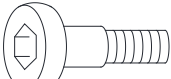

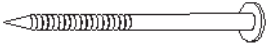
ROOF PANELS:

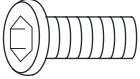

- Gently clean with an environmentally-friendly soap solution and water using a sponge or washcloth.
- Do not use abrasive materials, wire brushes, chemicals, harsh cleaners, or bleach.
- Rinse using a garden hose and air dry. If removed, ensure thoroughly dry prior to storage.
- Do not use pressure washer.

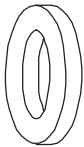
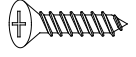
STRUCTURE:

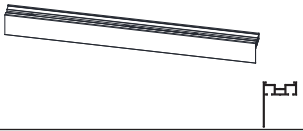
- Gently clean with an environmentally-friendly soap solution and water using a sponge or washcloth.
- Do not use abrasive materials, wire brushes, chemicals, harsh cleaners, or bleach.
- Rinse using a garden hose and air dry.
- Do not use pressure washer.
- If there are nicks, chips, and/or scratches see the part # of the paint in the parts list to obtain a matching touch-up paint.

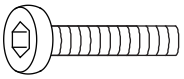
PART	PACKED IN BOX	QTY	DIAGRAM	PART	PACKED IN BOX	QTY	DIAGRAM
23-227 Corner Post A	1	4		23-197 Connecting Rod H1	2	2	
23-228 Left Lintel B	2	1		23-198 Connecting Rod H2	2	2	
23-229 Right Lintel C	2	1		23-199 Crank H3	2	1	
23-189 Front Lintel D1	2	1		23-200 Cap Liner I	2	2	
23-190 Front Lintel D2	2	1		23-234 Cap Liner I1	2	2	
23-230 Middle Lintel E	2	1		23-201 Base Plate J	2	4	
23-232 Rear Lintel F1	2	1		23-235 Connector L	2	2	
23-233 Rear Lintel F2	2	1		23-204 Spinners M	2	2	
23-195 Louver G	3	20		23-236 Rocker Connector N1	2	2	
	4	22					
23-196 Cover Plate G1	4	2		23-237 Rocker Connector N2	2	2	

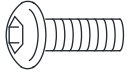
PART	PACKED IN BOX	QTY	DIAGRAM	PART	PACKED IN BOX	QTY	DIAGRAM
23-205 Bolt AA	2	40	 M6*15MM	23-212 M6 Washer HH	2	76	
23-206 Bolt BB	2	8	 M5*15MM	23-213 Plastic Plug II	2	12	
23-207 Bolt CC	2	4	 M6*10MM	23-214 Wrench JJ	2	1	
23-208 Screws DD	2	12	 M6*65MM	23-215 Allen wrench KK	2	1	
23-209 Bolt EE	2	168	 M5*8MM	23-216 Allen wrench LL	2	1	 4#
23-210 Nut FF	2	4	 M6	23-217 Allen wrench MM	2	1	 6#
23-211 M8 Washer GG	2	4		23-219 Bolt OO	2	16	 M5*25MM
23-223 Allen wrench RR	2	1	 3#	24-120 Rail tube P1	1	2	
24-121 Rail tube O1	1	2		24-122 Rail tube P2	1	2	
24-127 Rail tube O2	1	2		24-123 Bolt VV	2	8	 M6*25MM

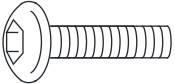
PART	PACKED IN BOX	QTY	DIAGRAM	PART	PACKED IN BOX	QTY	DIAGRAM
24-124 Bolt WW	2	12	 M6*15MM	24-126 M6 Washer UU	2	8	
24-125 Bolt XX	2	24	 M6*25MM				

Step 1

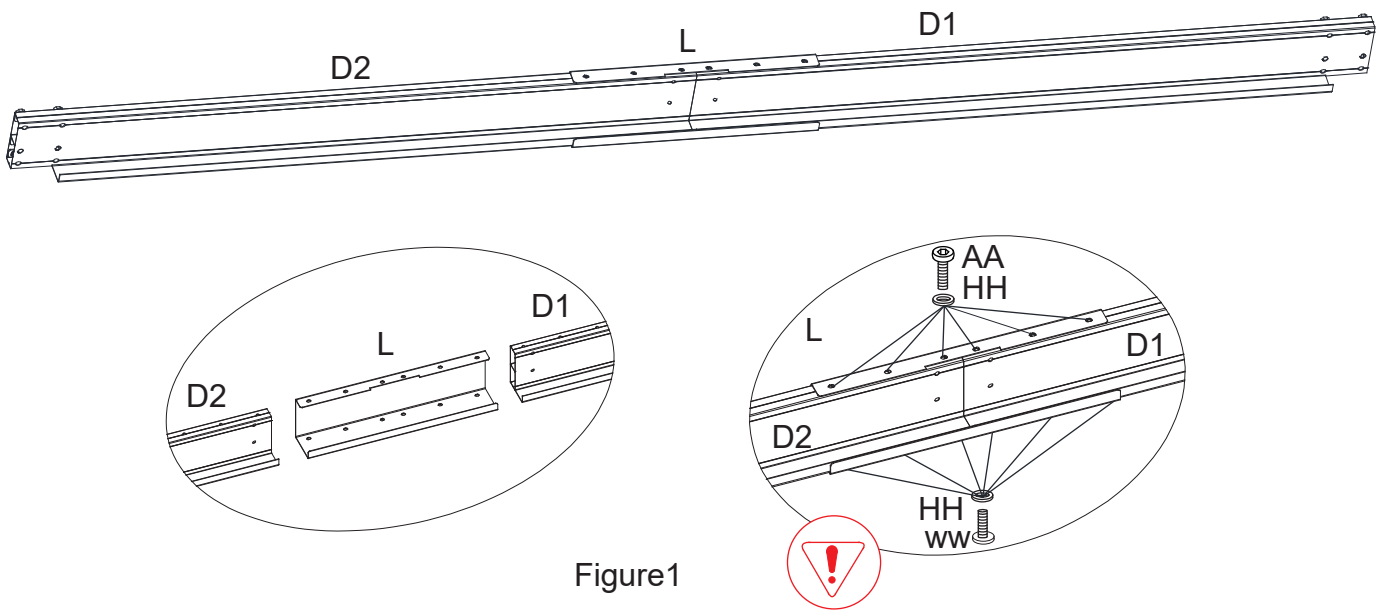

Figure1

1. Slide the Front Lintel (D1) and the Front Lintel (D2) into the Connector (L) by using Bolts (AA/WW) and Washer (HH). See Figure 1.

Step 2

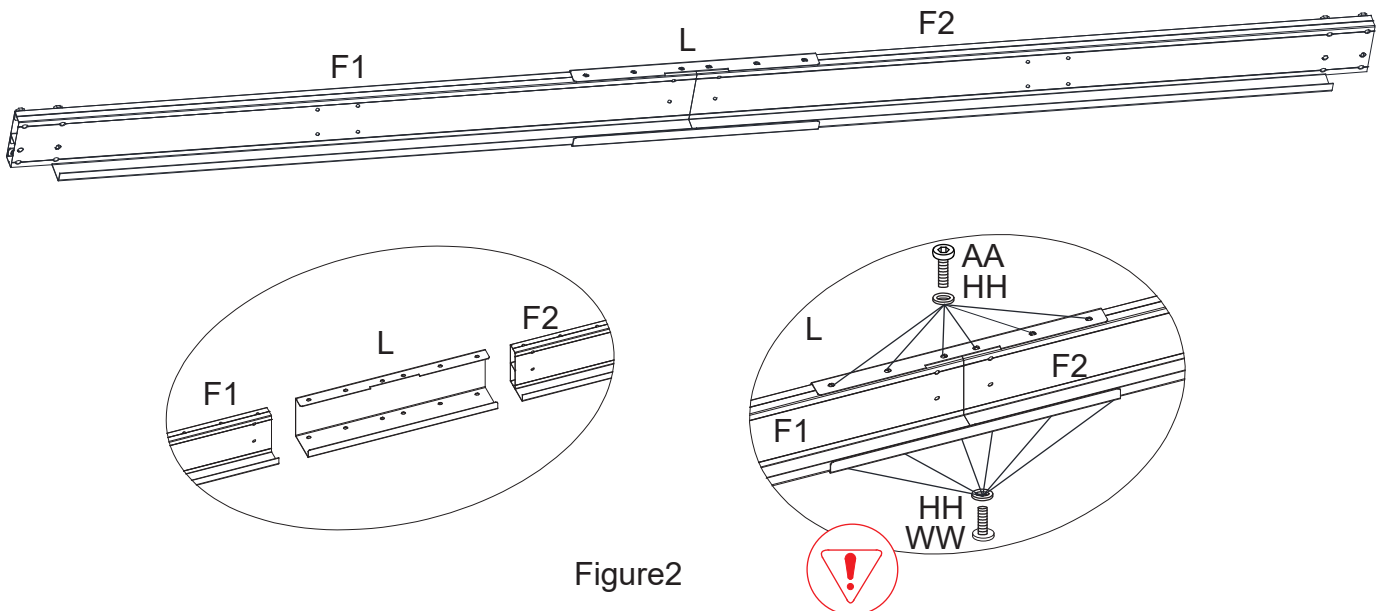
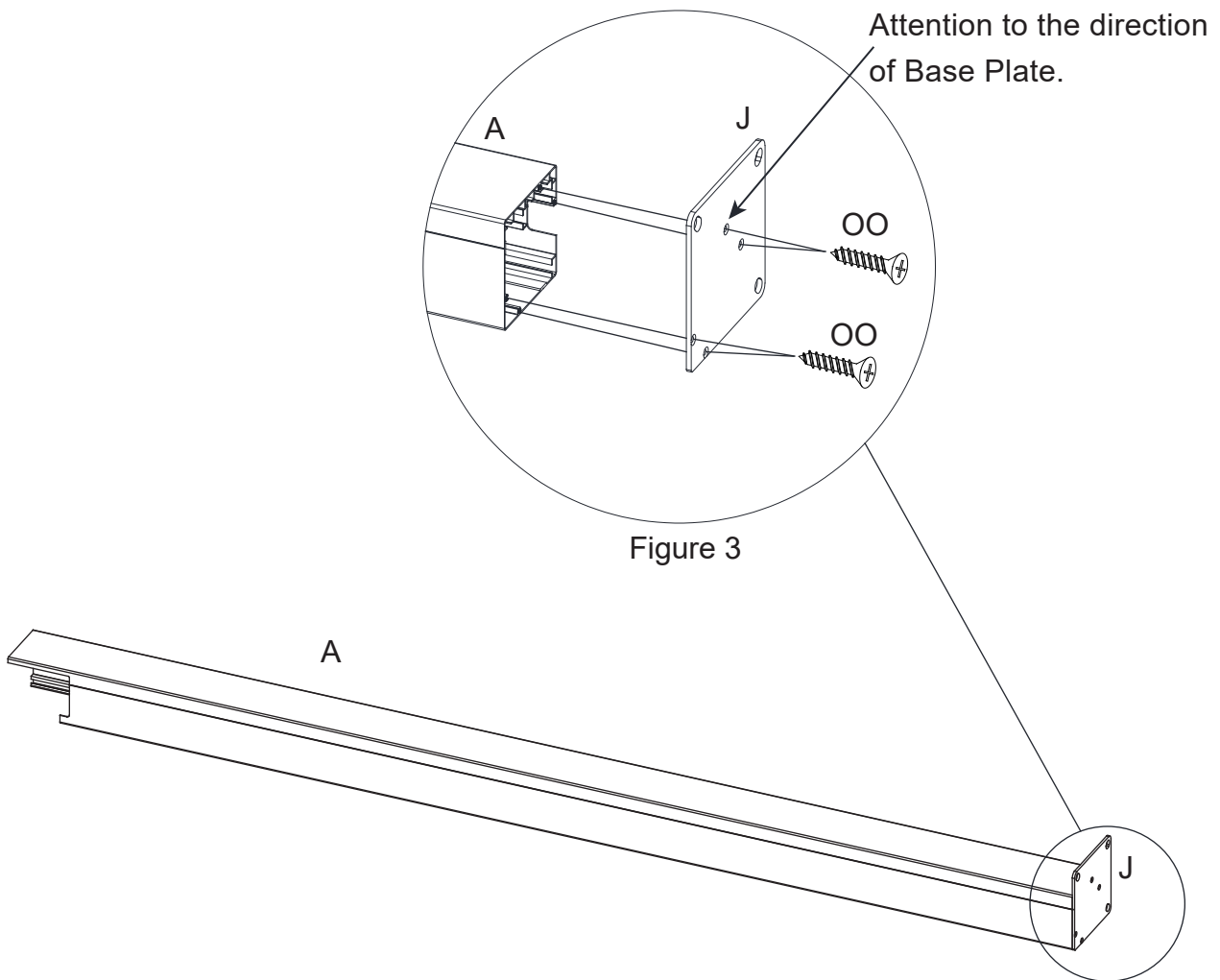

Figure2

2. Slide the Connector (L) into the Rear Lintel (F1) and Rear Lintel (F2) by using Bolts (AA/WW) and Washer (HH). See Figure 2.

Tips: Attention to the mounting direction of (L).

Step 3



3. Connect the Base Plate (J) and the Corner Post (A) by using Bolts (OO) .See Figure 3.

Step 4

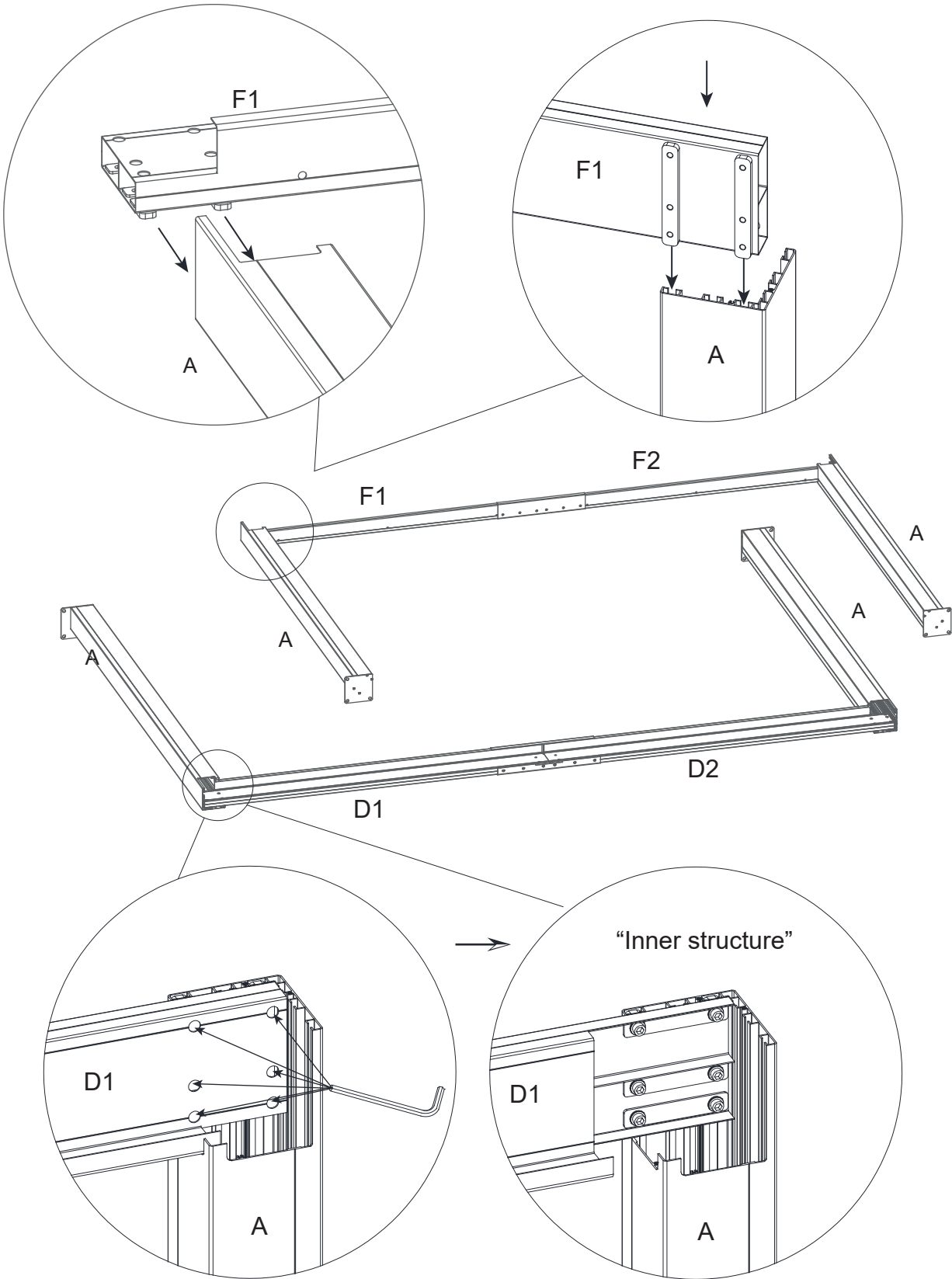

Figure 4

4. Slide both ends of the Lintel (D1/D2/F1/F2) into the built-in guide of the Corner Post (A), then tighten the bolts in the Lintel (D1/D2/F1/F2) by using Wrench .See Figure 4.

Step 5

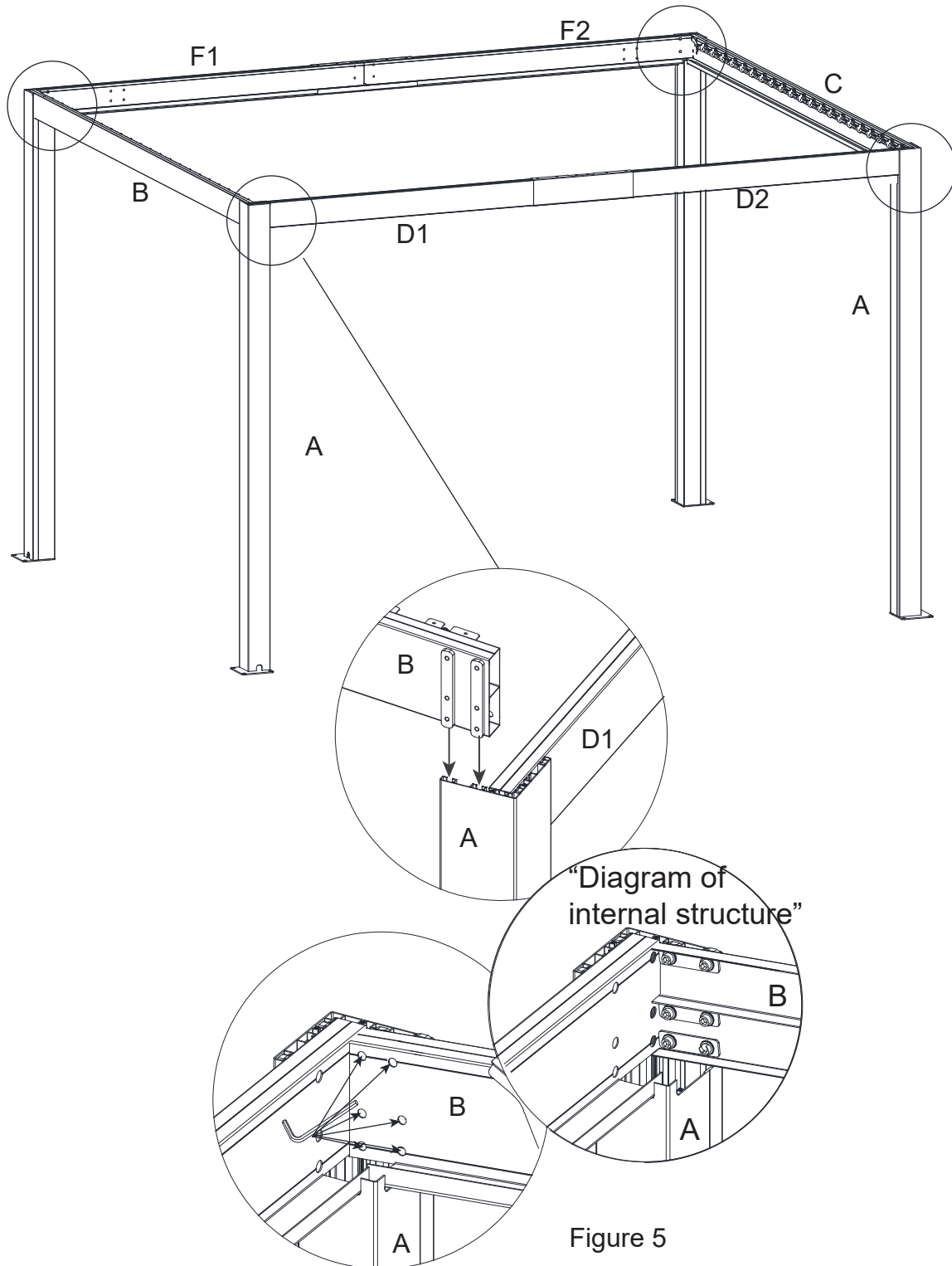

Figure 5

5. Slide one end of the Lintel (B/C) into the built-in guide of the Corner Post (A) and tighten it by Wrench, See Figure 5.

Step 6

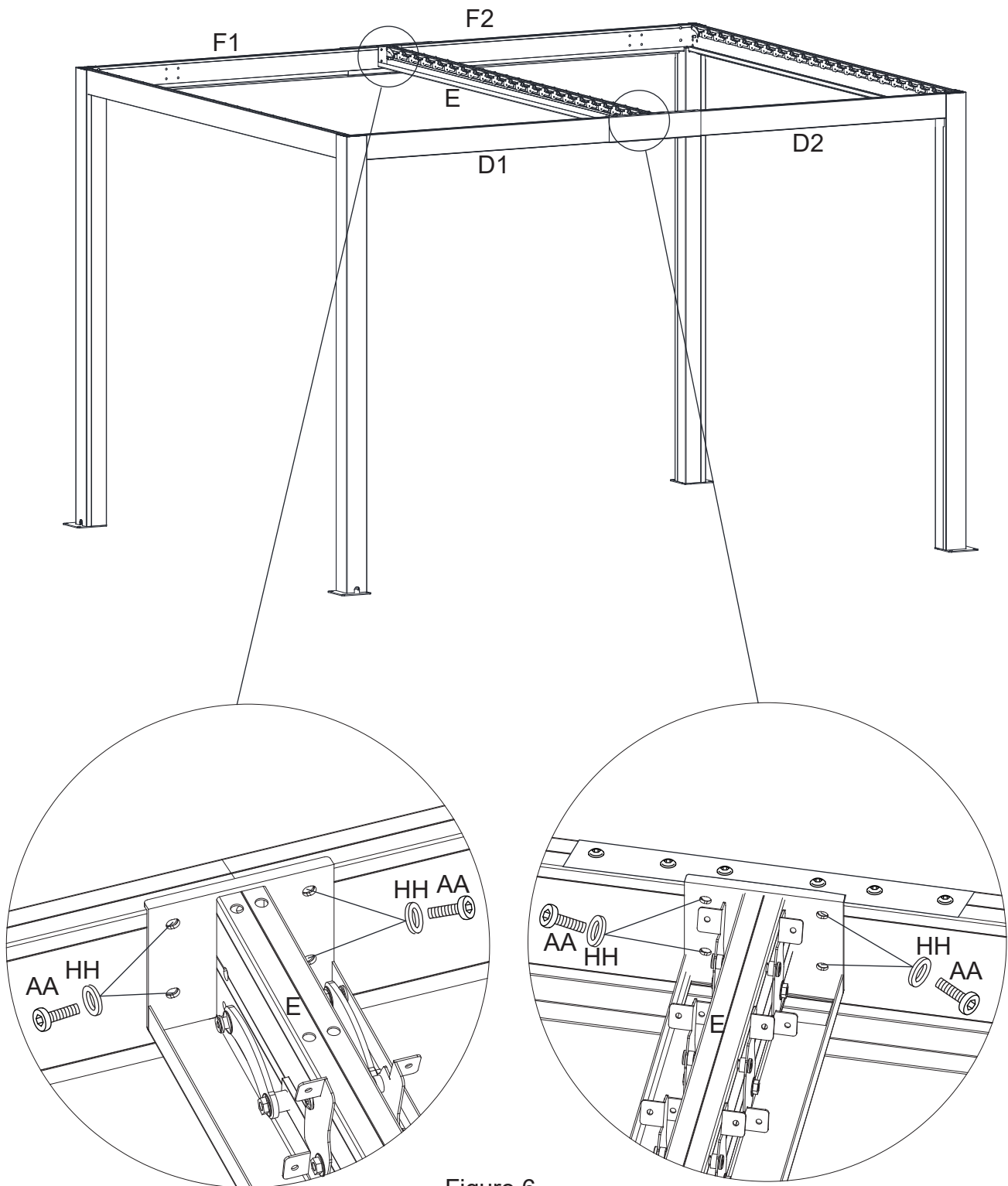
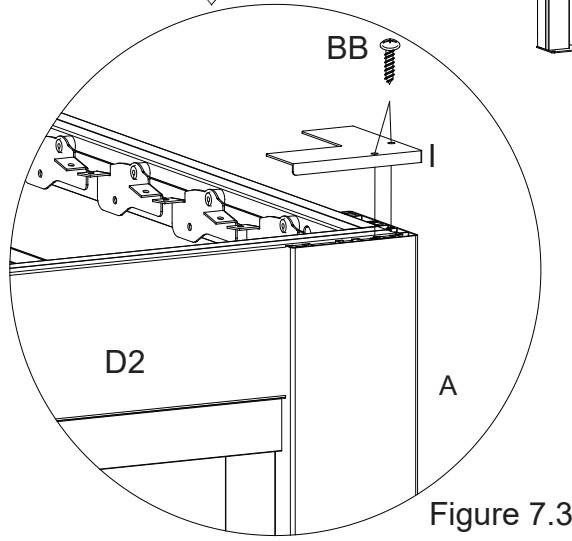
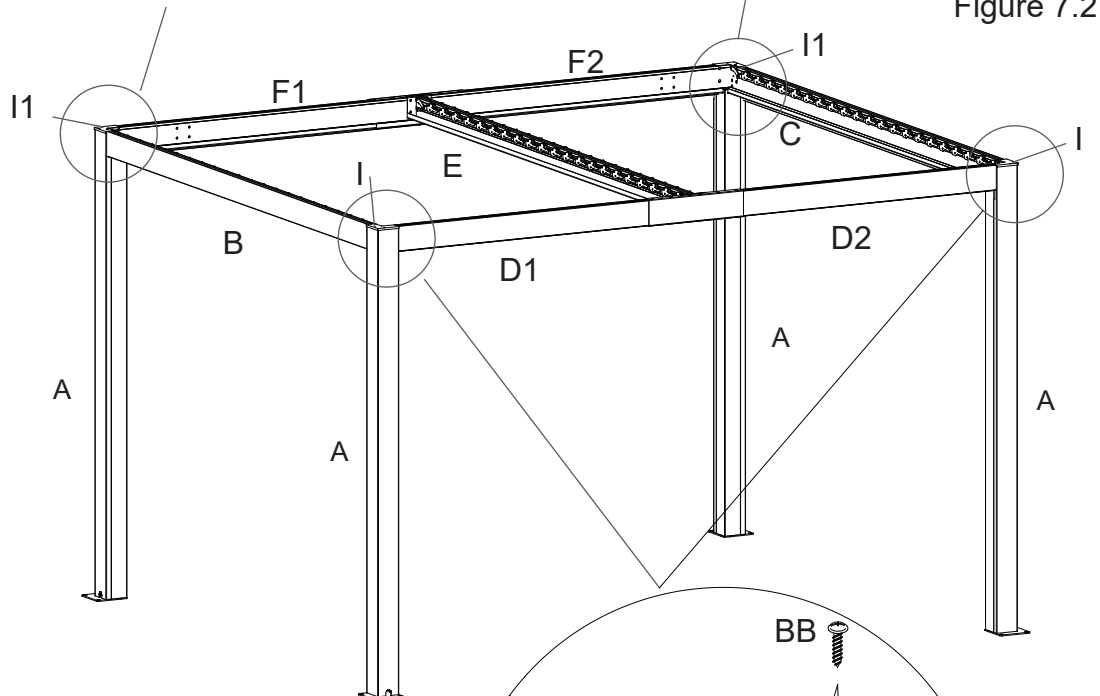
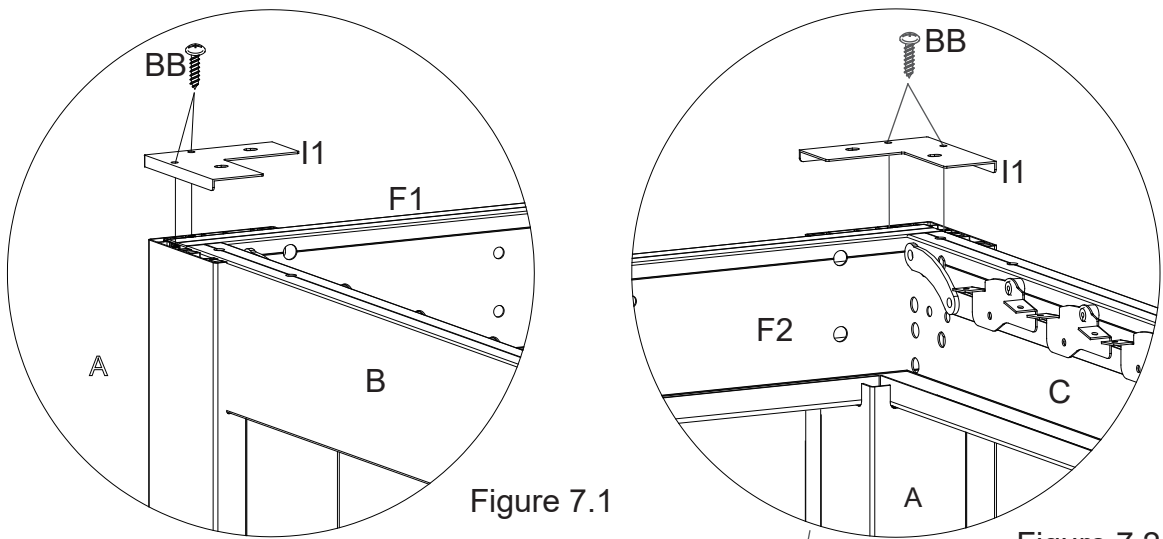

Figure 6

6. Connect one end of the Middle Lintel (E) with the Front Lintel (D1/D2), connect the other end of the Middle Lintel (E) with the Rear Lintel (F1/F2) by using Bolts (AA) and Washers (HH). See Figure 6.

Step 7



7. Connect the Cap Liner (I/I1) to the Post (A) and secure with Bolts (BB). See Figure 7.1-7.3

Step 8

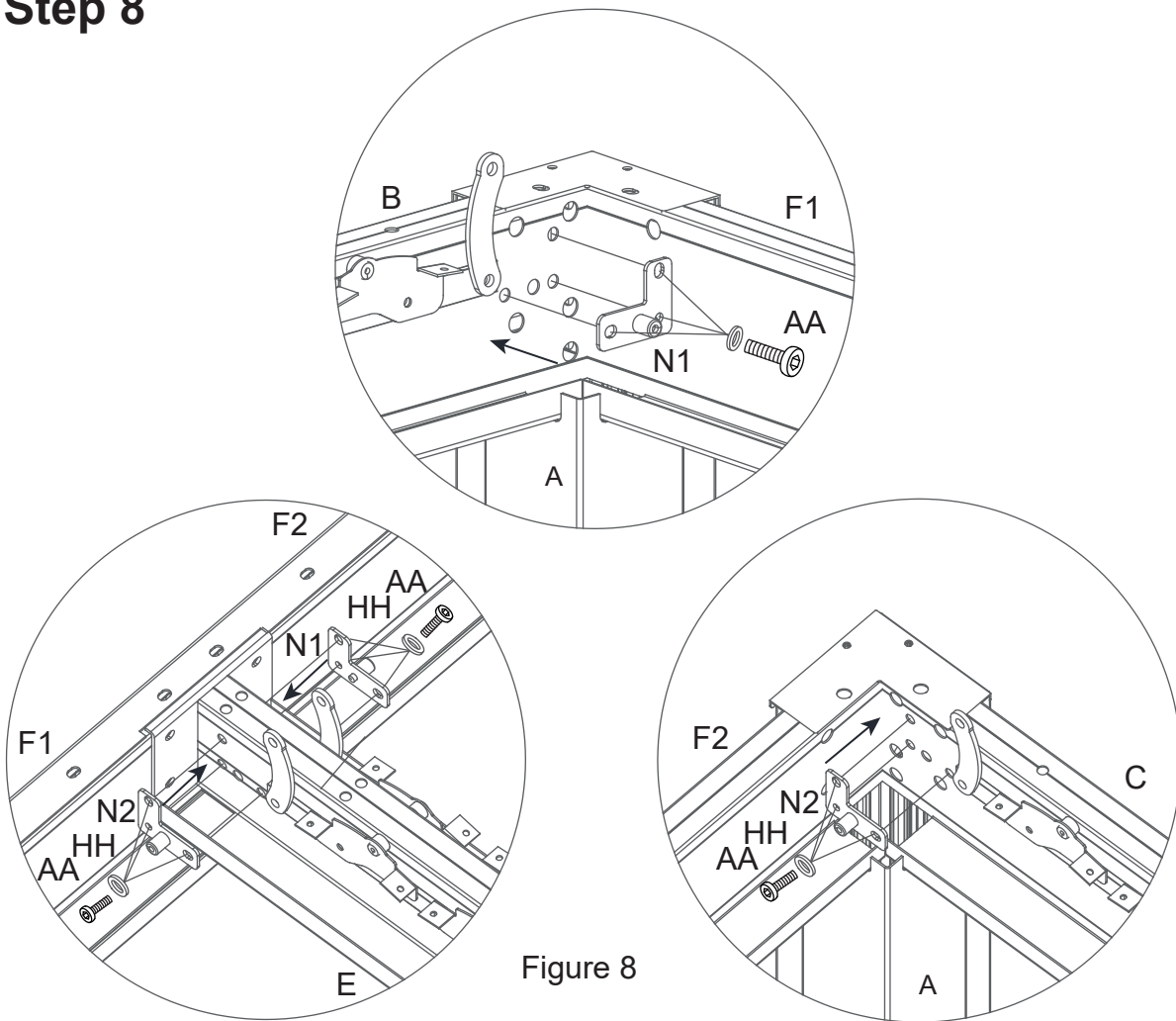
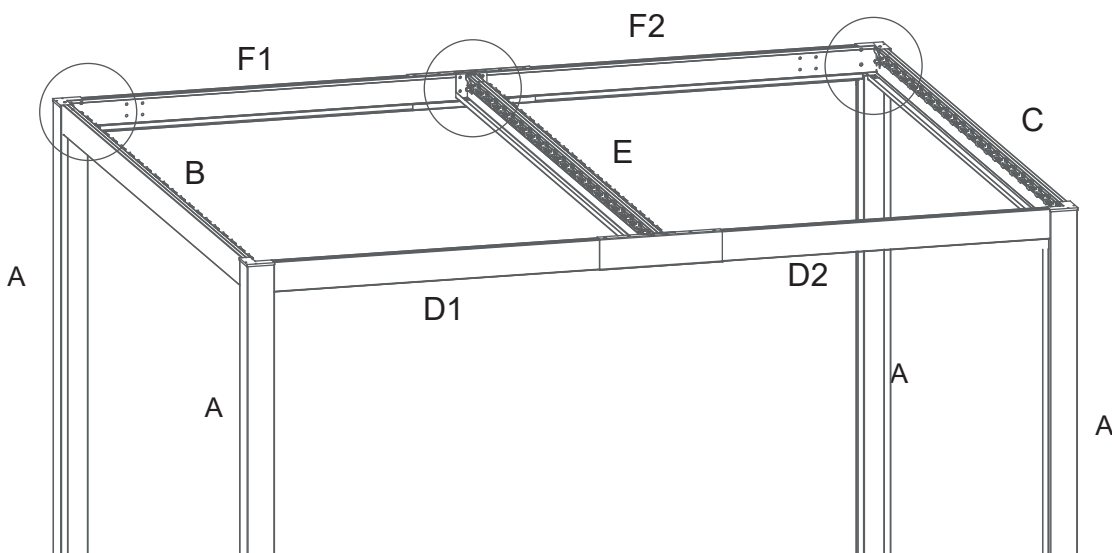

Figure 8



8. Attach the Rocker Connector (N1/N2) to the Lintels (B/C/E) using Bolts (AA) and Washers (HH). See Figure 8.

Step 9

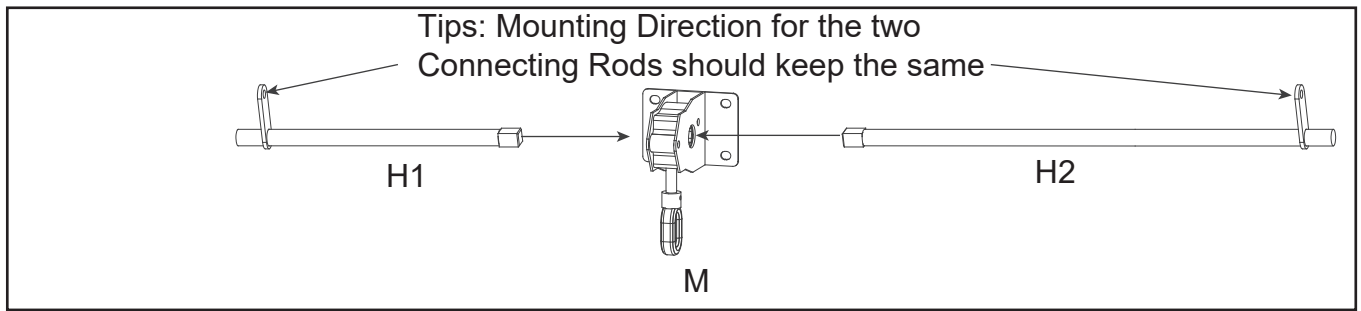

Figure 9.1

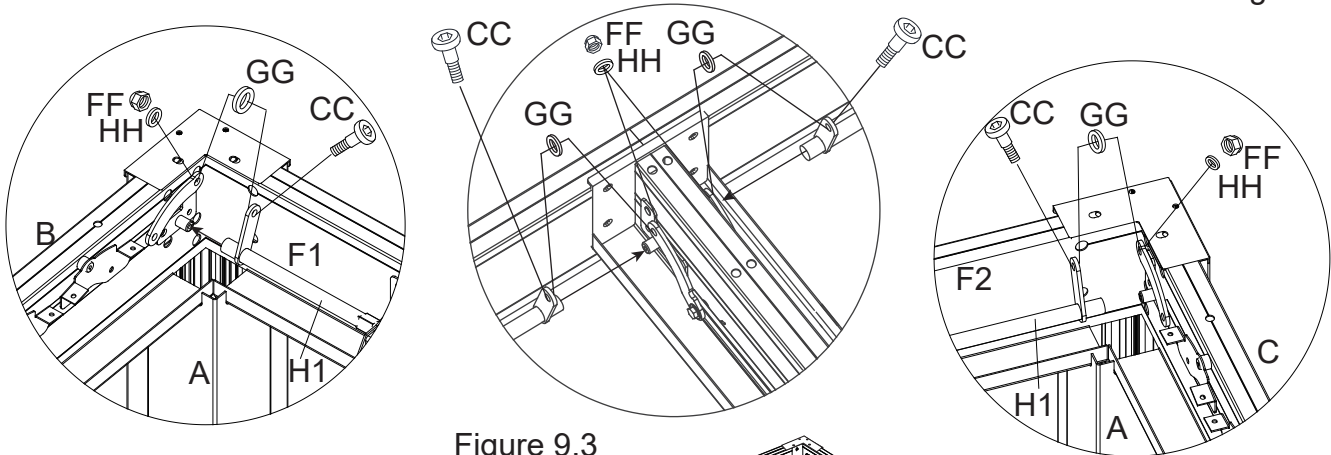

Figure 9.3

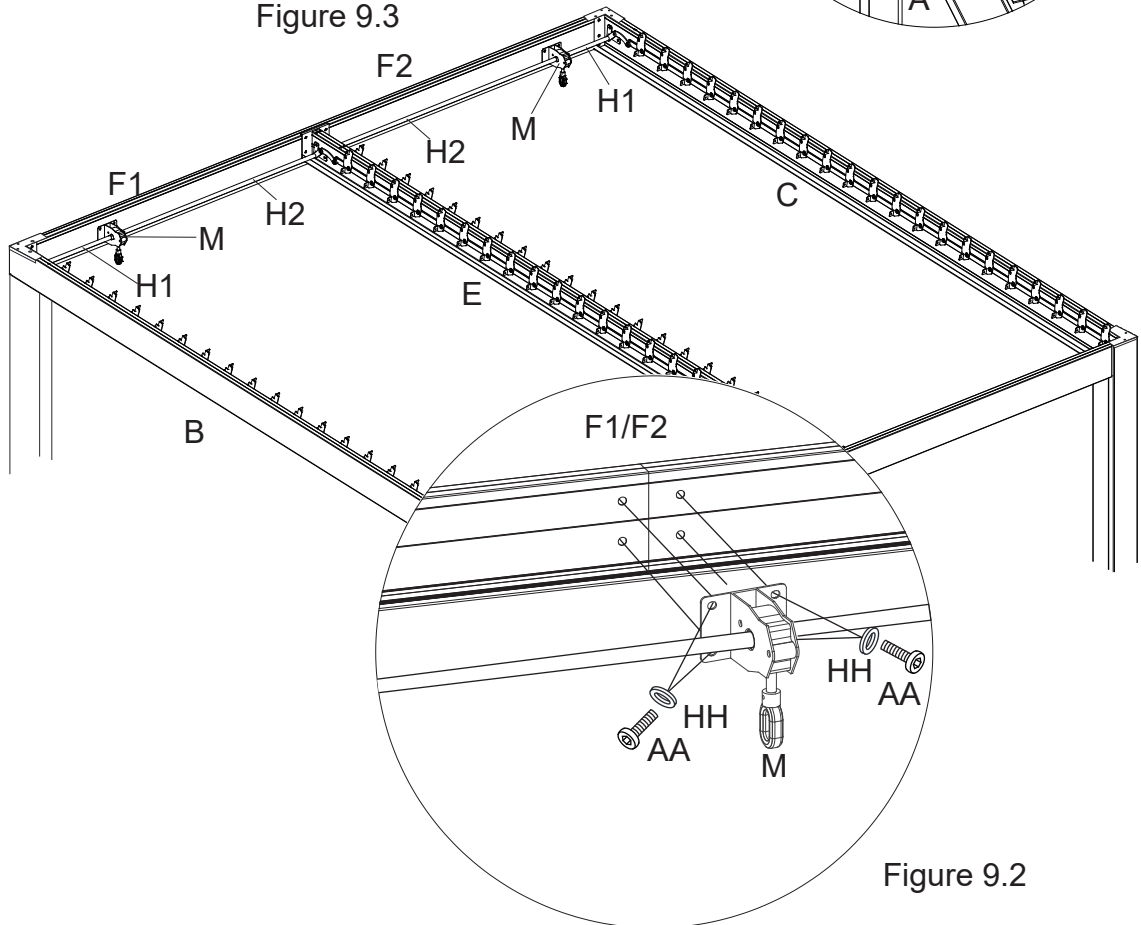

Figure 9.2

9. Insert one side of the two Connecting Rods (H1/H2) into the Spinner (M) and the other side into the Spinner (M), then attach the Spinner (M) to the Rear Lintel (F1/F2) and secure it with the Bolts (AA) and Washers (HH). Finally the other end of the Connecting Rods (H1/H2) is attached to the Lintels (B/C/E) using Bolts (CC), Washers (GG/HH) and Nuts (FF). See Figure 9.1- 9.3.

Step 10

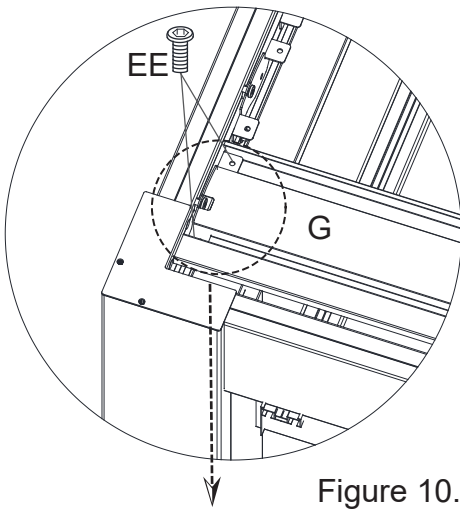

Figure 10.1

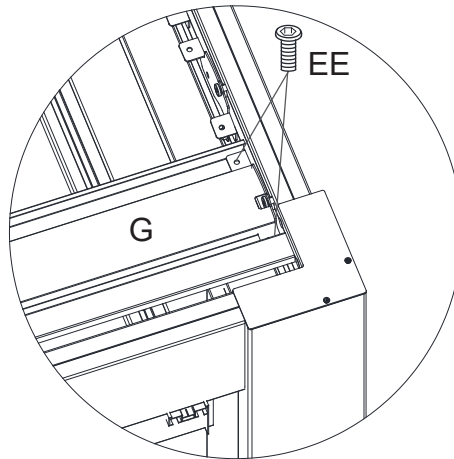

Figure 10.2

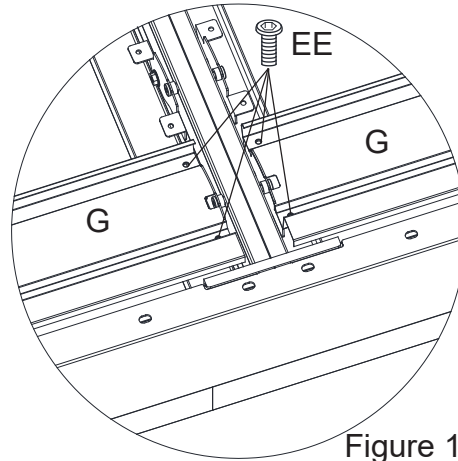
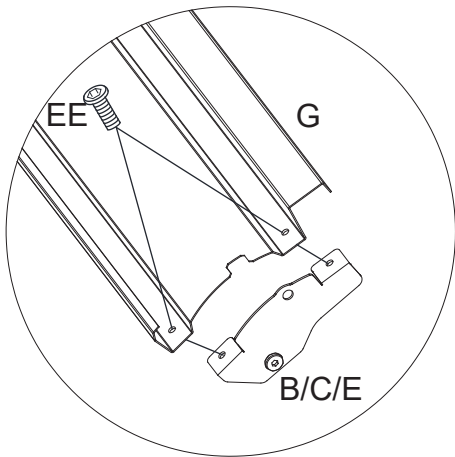

Figure 10.3

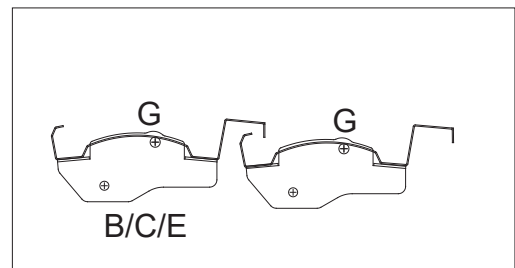
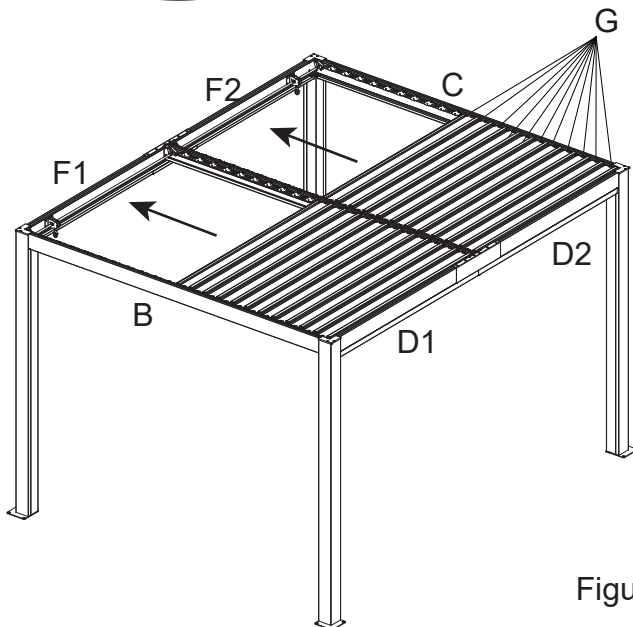
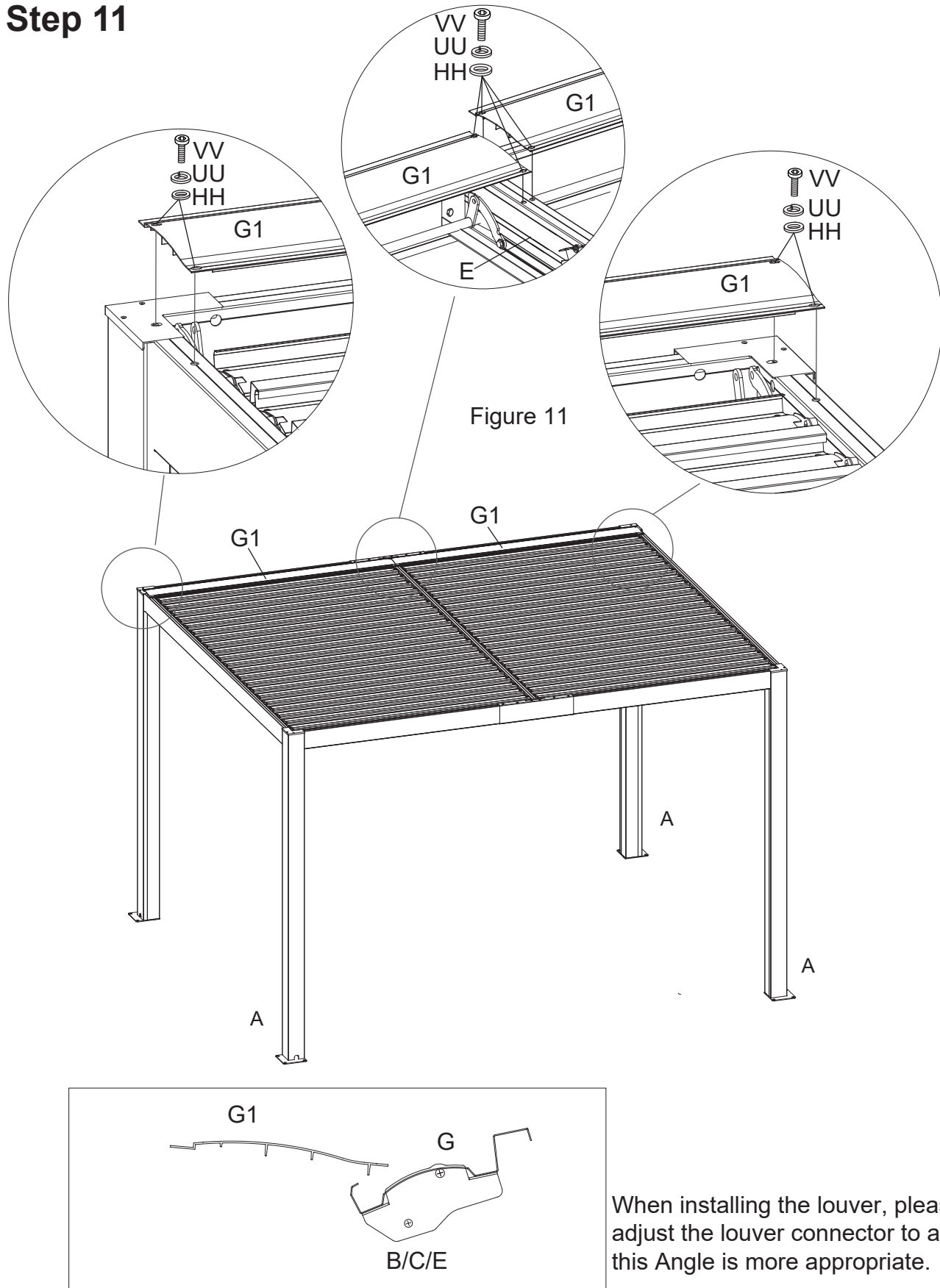

Figure 10.4

10.1. Connect the Louver (G) to the Lintels (B/C/E) and secure with the Bolts (EE). See Figure 10.1-10.3.

10.2. Assemble the other Louvers (G) in the direction of the arrows and secure them with Bolts (EE). See Figure 10.4.

Step 11



11. Connect the Cover Plate (G1) to the Lintels (B/C/E), securing it with Bolts (VV) and Washers (HH/UU). See Figure 11.

Step 12

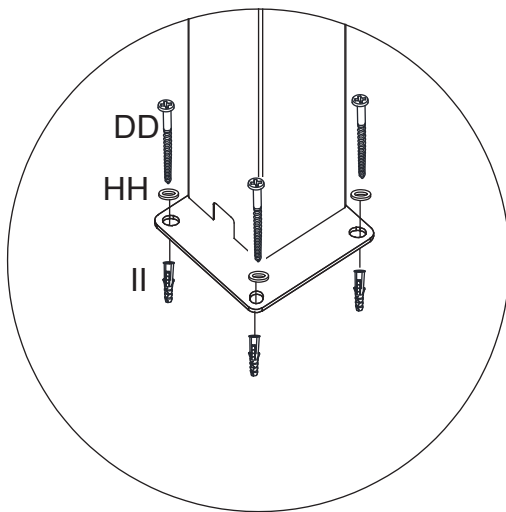
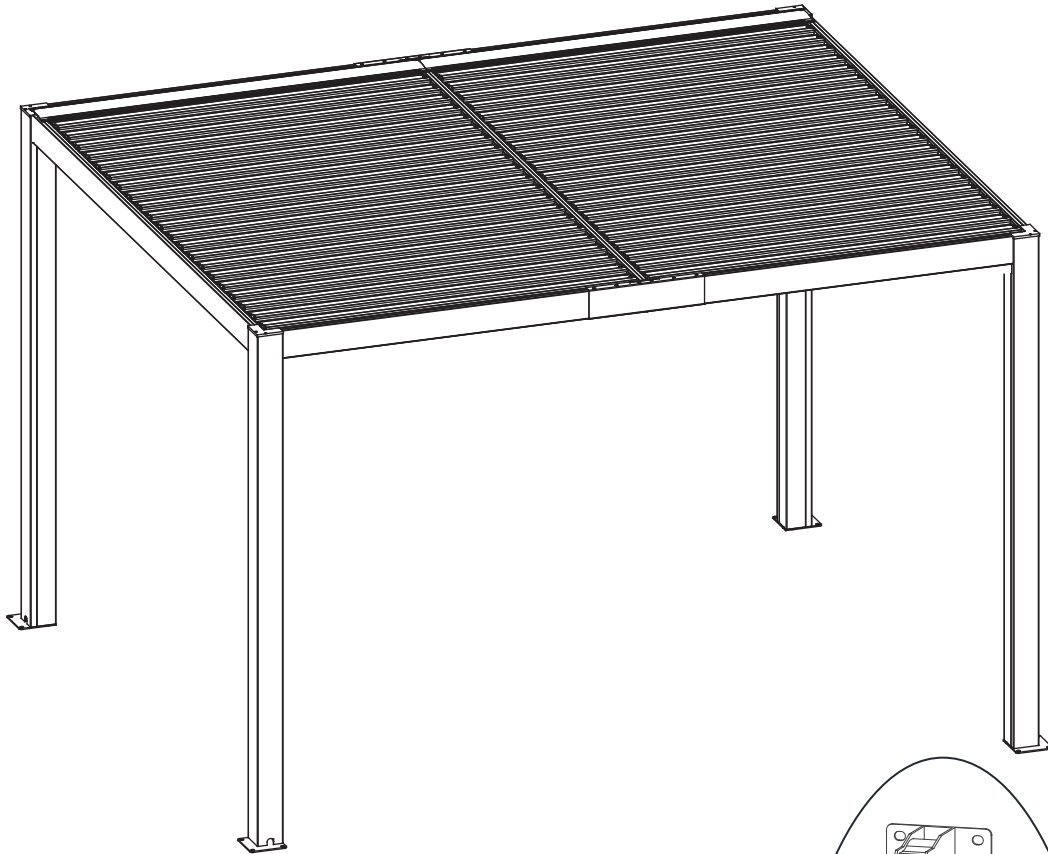

Figure 12.1

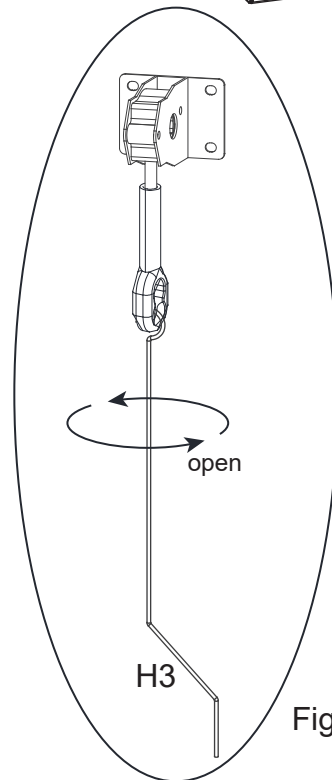

Figure 12.2

12.1 Secure the Pergola onto the deck or something by using Screws (DD), Washers (HH) and Plastic plugs (II) to make sure the steadiness of the item. See Figure 12.1.

12.2 Hang the Crank (H3) on the Spinners (M) and turn to open or close the louvers. See Figure 12.2.

Step 13

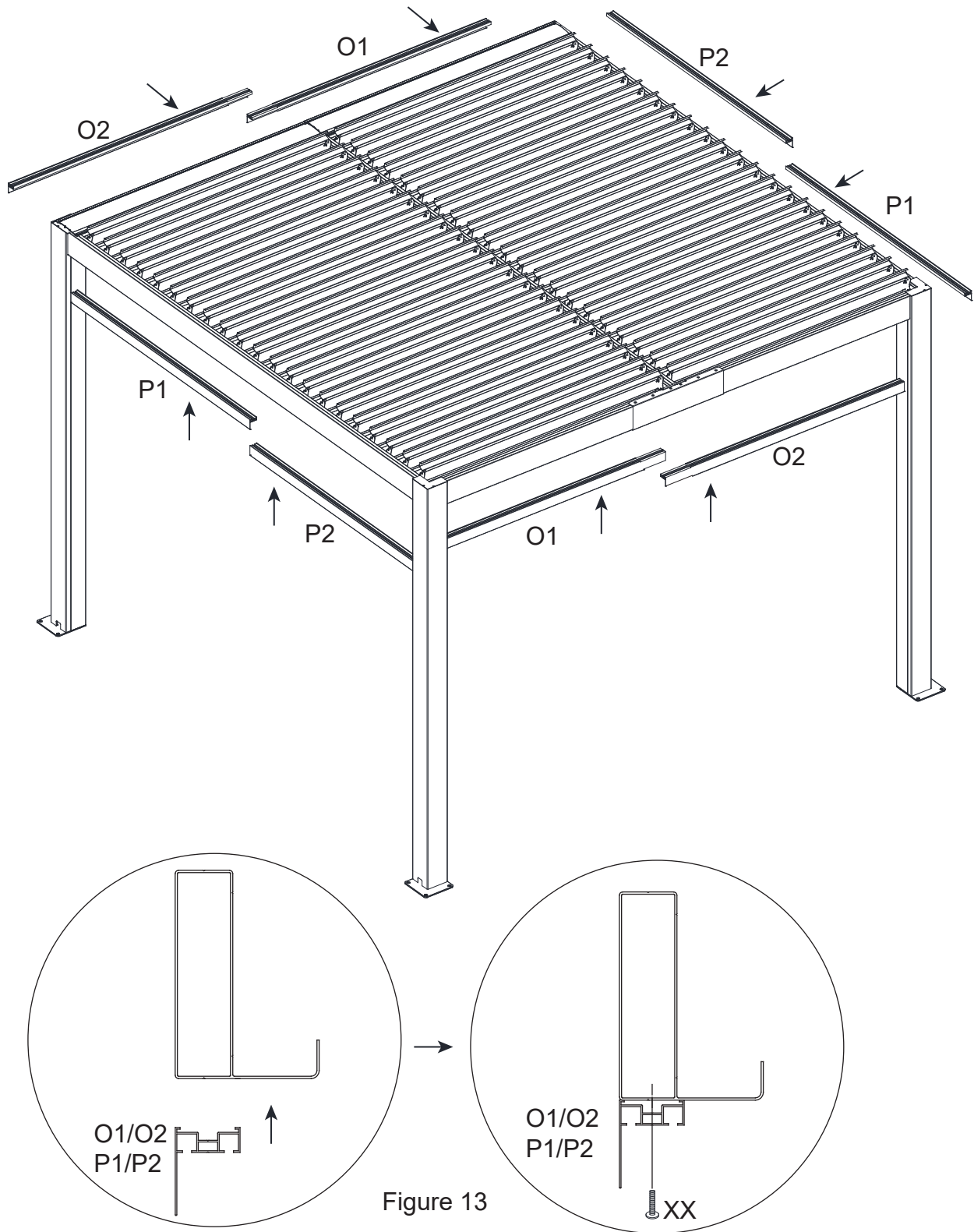

Figure 13

13. Connect the Rail tube (O1/O2/P1/P2) to the Lintel and fasten it with the Bolts (XX). See Figure 13.

Warm Tips:

Please close the louvers when it rains.

Note: After the rain, please open the louvers slowly to prevent the residual rain water from splashing.

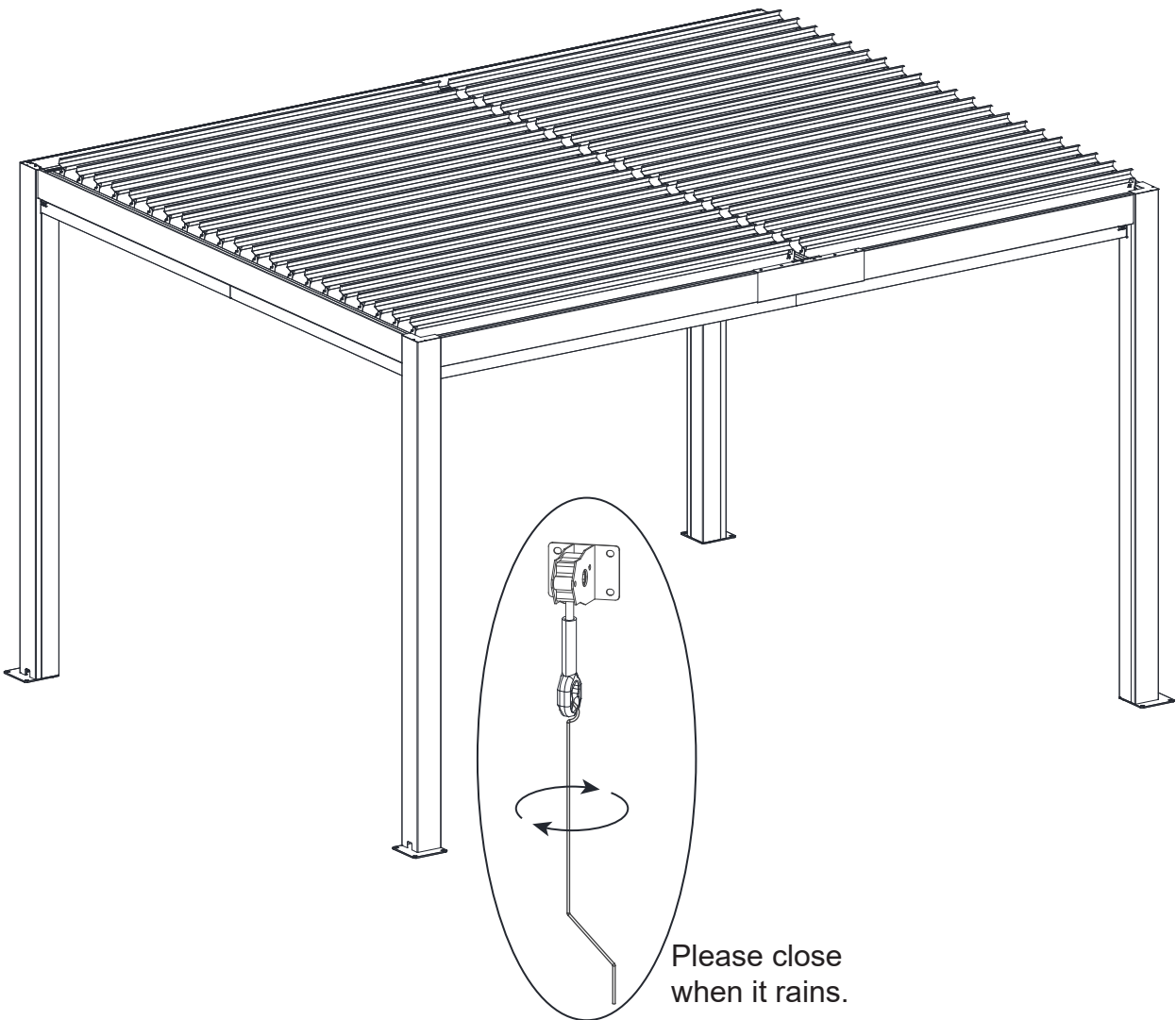
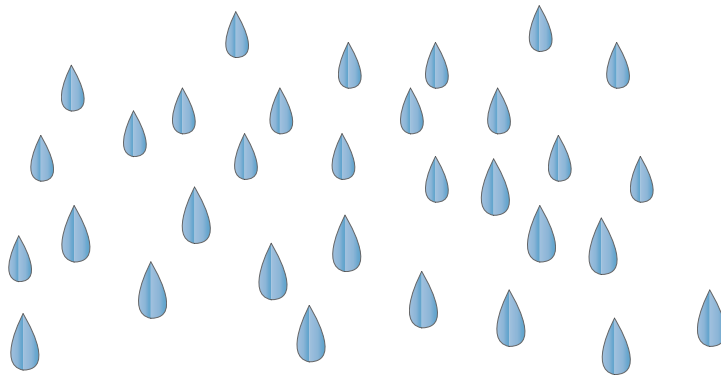

WARRANTY

WARRANTY

Carefully inspect the contents of the package for missing or damaged components. If any parts are missing or damaged, **do not return the product to the place of purchase**; instead, contact the Gazebo Penguin Customer Experience Department

Montreal: (514) 276-5643

Elsewhere in Canada and the United States: 1-800-737-7174

info@gazebopenguin.com

This product has been designed and manufactured to meet the highest standards of quality and durability. Subject to the "Warranty Conditions" and "Warranty Limitations" sections below, it is warranted against defects in material or workmanship for:

- **1 YEAR ON MANUFACTURING DEFECTS**

In the event that the product is damaged or the warranty period has expired, please contact the Penguin Gazebo Customer Experience Department for a complete list of replacement parts and prices.

WARRANTY LIMITATIONS AND EXCLUSIONS

1. This product is not warranted against damage caused by wind, falling objects, fire, animals, vegetation, vandalism and extreme weather conditions.
2. Collapses of shelters caused by snow, ice and wind accumulation
3. The roof **must be kept free of snow and ice accumulation at all times.**
4. Any damage that may be caused by snow and ice accumulation is not covered by the warranty. Snow and ice must be removed from the roof, from right to left, in five feet (5) sections at a time.
5. Removal of snow and ice from the product from the inside may damage the product and may cause serious injury to the person(s) involved in the removal.
6. It is strongly recommended that the product not be placed adjacent to buildings or trees as snow or ice may slide off the roof. In the event that the product is placed adjacent to a building or tree, additional precautions must be taken to ensure that there is no accumulation of snow or ice that could cause excessive weight to the product.
7. The product is warranted only if installed in accordance with Gazebo Penguin's written instructions included with the product.
8. Leaks due to heavy rainfall may occur. Please refer to the instruction manual for window positions and information on how to drain water.
9. The product is not guaranteed if it has been anchored improperly.
10. We reserve the right to replace or repair any defective product or part at our sole discretion.
11. No modifications or additions to the product are permitted. This will void your warranty.